

VALCON

VALTAI CONTROLLER

Vehicle Specific Manual



Pursuing the Ultimate in Engine Performance and Efficiency
HKS Company Limited

E05171-T22020-00
April, 2010
Ver.3-1.01

NOTICE

Thank you for purchasing the HKS VALCON system. For safe usage and understanding of the functions of this product, please read both the operation and installation manuals before installation and use. This manual explains the installation of the VALCON unit that is not mentioned in the operation manual.

APPLICATION

MAKER	TOYOTA
VEHICLE	CELICA
YEAR	1999.9 - 2006.4
MODEL	ZZT230
ENGINE	1ZZ-FE

WARNING

- Do not use on engines in which the pistons may come in contact with the valves due to the camshaft timing changes. If this happens, the engine may become damaged.

REQUIRED OPTIONAL PARTS

An optional universal harness and adapter (sold separately) are required for installation. Purchase the required harness and adapter listed below.

Required Optional Parts

PART No.	PRODUCT	Number of use
45999-AK023	VALCON II Universal Harness 1L	1
45999-AK025	VALCON II ADAPTER	1

VALCON INPUT AND OUTPUT SIGNAL

1 VALCON Unit Connectors

Viewed from the wire side of the VALCON main unit harness.

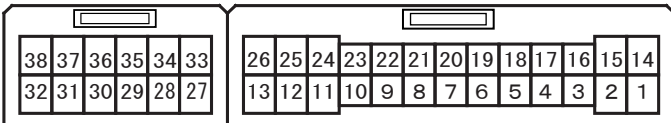

26 Pin Connector (Wire colors of Universal Harness 1)

No.	Description	Color	Description
1	GND	Black	Control ground
2	GND	Green	Pressure sensor ground
▲3	NE-	Red/Black	Crankshaft angle signal (-)
▲4	G1 OUT	Orange/Black	Camshaft angle signal 1 output
▲5	G2 OUT	Blue/Black	Camshaft angle signal 2 output
▲6	G GND	Red/Green	Camshaft angle signal (-)
7	REV OUT	White	RPM signal output
8	OP OUT1	Brown	Voltage output 1 for data logger
9	OP OUT2	Orange	Voltage output 2 for data logger
10	SOL2 IN	Yellow/White	Solenoid 2 input
11	SOL2 OUT	Yellow/Black	Solenoid 2 output
12	SOL2 GND	Green/Black	Solenoid 2 ground
13	POWER GND	Black/White	Power ground
14	IG	Red	Ignition power supply
15	+5V	Yellow	5V power supply for pressure sensor
▲16	NE+	Gray	Crankshaft angle signal (+)
▲17	G1 IN	Orange/White	Camshaft angle signal 1 input
▲18	G2 IN	Blue/White	Camshaft angle signal 2 input
19	AFM/OP IN1	Purple	Air flow sensor input / Option input 1
20	BOOST/OP IN2	Blue	Pressure sensor input / Option input 2
21	THROTTLE	Pink	Throttle sensor input
22	WATER	Light Blue	Water temperature sensor input
23	SOL1 IN	Brown/White	Solenoid 1 input
24	SOL1 OUT	Brown/Black	Solenoid 1 output
25	SOL1 GND	Green/White	Solenoid 1 ground
26			Not used

12 Pin Connector (Wire colors of Universal Harness 2)

No.	Description	Color	Description
27	SOL4 GND	Green/Black	Solenoid 4 ground
28	SOL4 OUT	Yellow/Black	Solenoid 4 output
29	SOL4 IN	Yellow/White	Solenoid 4 input
30			Not used
▲31	G3 OUT	Orange/Black	Camshaft angle signal 3 output
▲32	G4 OUT	Blue/Black	Camshaft angle signal 4 output
33	SOL3 GND	Green/White	Solenoid 3 ground
34	SOL3 OUT	Brown/Black	Solenoid 3 output
35	SOL3 IN	Brown/White	Solenoid 3 input
36			Not used
▲37	G3 IN	Orange/White	Camshaft angle signal 3 input
▲38	G4 IN	Blue/White	Camshaft angle signal 4 input

Universal Harness 1L and 2L have shielded and labeled white wires with "▲" mark. They are also labeled with the names of each corresponding signal at the end of each wire.

2. Universal Harness 4 pin connector



Universal Harness 1 & 2 connectors as viewed from the opposite side of the wire harness.

4 Pin Connector (Wire colors of Universal Harness 1)

No.	Description	Color	Description
1	SOL1 IN	Brown/White	Solenoid 1 input
2	SOL2 IN	Yellow/White	Solenoid 2 input
3	SOL1	Brown/Red	Solenoid 1 Power Supply / Ground
4	SOL2	Yellow/Red	Solenoid 2 Power Supply / Ground

4 Pin Connector (Wire colors of Universal Harness 2)

No.	Description	Color	Description
1	SOL3 IN	Brown/White	Solenoid 1 input
2	SOL4 IN	Yellow/White	Solenoid 2 input
3	SOL3	Brown/Red	Solenoid 1 Power Supply / Ground
4	SOL4	Yellow/Red	Solenoid 2 Power Supply / Ground

3. Other Wires on the Universal Harness

Universal Harness 1

No.	Description	Color	Description
	SOL1-2	Red/Yellow	Solenoid 1-2 Power Supply / Ground

Universal Harness 2

No.	Description	Color	Description
	SOL3-4	Red/Yellow	Solenoid 3-4 Power Supply / Ground

LOCATION OF ECU

Refer to the "Location of ECU" section and confirm its location.
The ECU is located engine room, passenger-side ⑦.

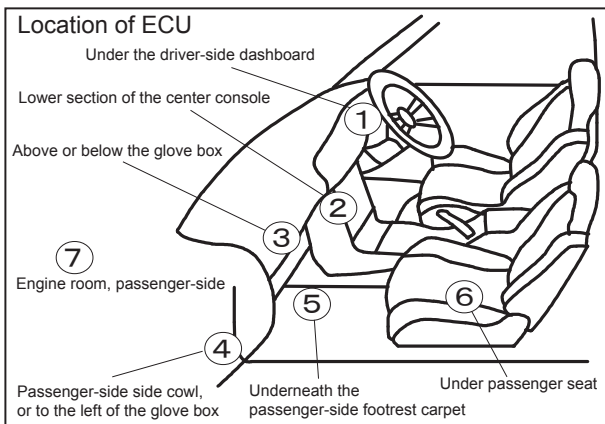

INSTALLATION

WARNING

- Do not use on engines in which the pistons may come in contact with the valves due to the camshaft timing changes. If this happens, the engine may become damaged.
- During operation, the adapter unit temperature will increase. Make sure the adapter is mounted away from flammable objects, as it can cause a fire.

1. Disconnecting the Battery Terminal

- (1) Disconnect the negative terminal from the battery.

2. Wiring

2.1 Bullet connector installation.

Installation of male bullet connector

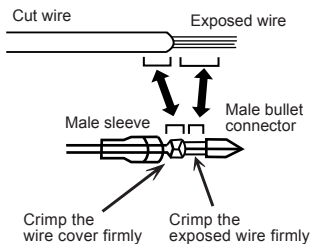

- ① Cut the wire.
- ② Strip the wire insulation.
- ③ Insert the wire through the sleeve before crimping the bullet connector.
- ④ Crimp the bullet connector to the wire.
- ⑤ Crimp the bullet connector to the wire cover.
- ⑥ Cover the crimped portion with the sleeve.

Installation of female bullet connector

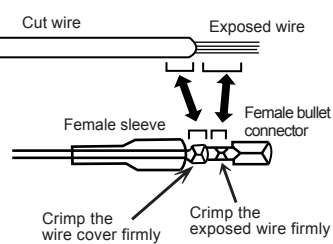

2.2 Installing Splices

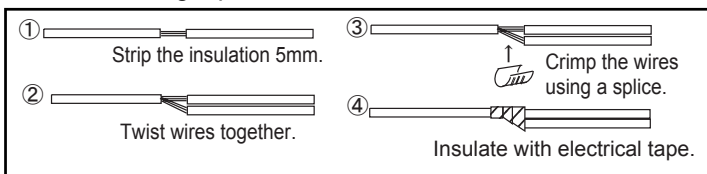

- ① Strip 5mm of the wire insulation as shown above.
- ② Connect the wire to the uncovered area by twisting the wires together.
- ③ Crimp the twisted wires together using a splice.
- ④ Insulate the spliced wires with electrical tape.

3. Wiring Diagram Key

3.1 Diagram indicators

The following indicators are used in the wiring diagram.

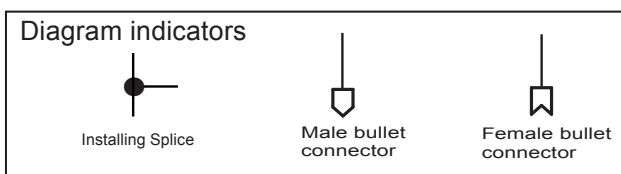

3.2 Connector Direction

Direction of the connector

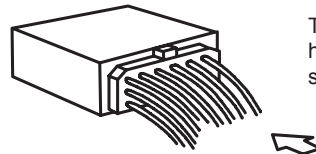

The pin numbers on the connector harnesses are viewed from the wire side of the connector.

4. Wiring

Connect Universal Harness 1L using splices and/or Solder.

4.1 Wiring Layout

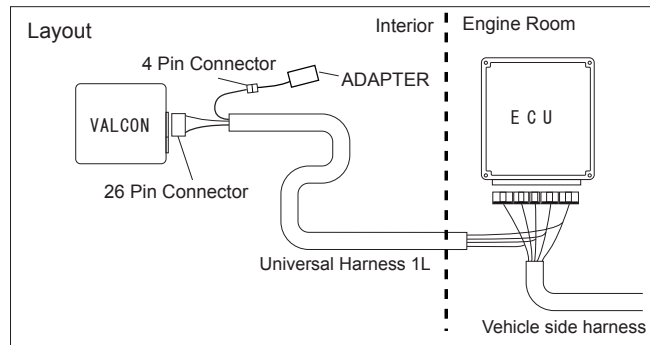

4.2 Wiring Method

- (1) Refer to the "Location of ECU" section and confirm its location.
- (2) Pull Universal Harness 1L (sold separately) from the cabin to the engine compartment or from the engine compartment to the cabin.
- (3) Connect Universal Harness 1L using splices and bullet connectors in accordance to the wiring diagram on page 5. Universal Harness 1L is available separately.

(P2 × 8, P3 × 3, P4 × 3, P5 × 3, P6 × 3)

- If a wire crimper is not available, use needle nose pliers and solder the splice to the wire. Make sure that the wire does not come out of the splice.

- (4) Insulate the connected area with electrical tape to prevent a short.
- (5) Check to make sure the following wires of the Universal Harness 1L's 4 pin connector are connected: Brown/Red wire to Brown/Red wire, and Yellow/Red wire to Yellow/Red wire.

- If the connection is incorrect, connect them as shown below.

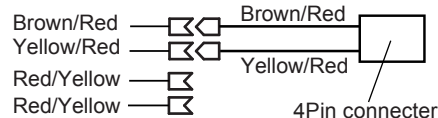

- (6) Insulate unused wires with electrical tape to prevent electrical shorts.
- (7) Connect the 26 pin connector of Universal Harness 1L to the VALCON unit. (P1 × 1)
- (8) Connect the 4 pin connector of Universal Harness 1L to the adapter.

5. Mounting the Unit

- (1) Choose a mounting location for the VALCON unit taking into consideration the length of the harness.
- (2) Secure the harness with tie wraps. (P7)

6. Complete the Installation

- (1) Reinstall all removed factory parts.
- (2) Reconnect the negative terminal to the battery.

VALCON Universal Harness Wiring Diagram for ZZT230 CELICA

