

HEAD BOLT UPGRADE KIT INSTALLATION MANUAL



Read this manual before use.

Have a professional install this product.

Keep this manual after reading.

This product is only for the vehicle mentioned below.

If your vehicle is different from the application of this product, contact the seller immediately.

| | |
|-----------------|---|
| NAME OF PRODUCT | HEAD BOLT UPGRADE KIT |
| USAGE | AUTOMOBILE PART |
| PART NUMBER | HEAD BOLT UPGRADE KIT 22999-AM001 |
| | HEAD GASKET + HEAD BOLT KIT 23009-AM001, 23009-AM002, 23009-AM003 |
| MANUAL NUMBER | E04145-M30010-00 |
| APPLICATION | MITSUBISHI LANCER EVOLUTION IV~IX (CN9A, CP9A, CT9A) |
| ENGINE | 4G63 |
| YEAR | CN9A 1996/08-1997/12, CP9A 1998/01-1998/12, CT9A 1999/01-2007/09 |
| REMARKS | <ul style="list-style-type: none"> • This product was designed for use with the following HKS Head Gaskets only. (23001-AM003, 23001-AM004, 23001-AM005) • Use engine oil as lubrication when tightening bolts. • The bolts are made of a high strength material and do not require any additional anti-rust processes. • Follow the Mitsubishi Service Manual for procedures not mentioned in this manual. |

REVISION OF MANUAL

| Rev. Number | Date | Details |
|-------------|---------|-------------|
| 3-3.01 | 2009/07 | 1st Edition |
| | | |

Prefix

Thank you for purchasing the HKS HEAD BOLT UPGRADE KIT.

Installation must be done by a professional installer. After installation, follow the instructions in this manual. Please read this manual before installation.

Features of the product

- Bolts Due to the use of upgraded materials, hardness and axis dia. the strength is increased about 70% and the tightening force is greatly increased over stock. The bolts can be reused as long as the proper torque spec is used.
- Washers Do to the use of upgraded materials, hardness and surface treatment, it protects against stretching and cracking. The bolt seat surface is stronger against scratching due to the Tufftride coating.

| |
|---------------|
| NOTICE |
|---------------|

This manual assumes that you have and know how to use the tools and equipment necessary to safely perform service operations on your vehicle. This manual assumes that you are familiar with typical automotive systems and basic service and repair procedures. Do not attempt to carry out the operations shown in this manual unless these assumptions are correct. Always have access to a factory repair manual. To avoid injury, follow the safety precautions contained in the factory repair manual.

PARTS LIST

| NO. | Part Number | Descriptions | QTY | Remarks |
|-----|------------------|--------------------------|-----|---------|
| 1 | G11151-M30020-00 | UPGRADED HEAD BOLT | 10 | |
| 2 | G11152-M30010-00 | WASHER for UPGRADED BOLT | 10 | |
| 3 | E04145-M30010-00 | MANUAL | 1 | |

SPECIFICATIONS

| Head Bolt | HKS | MITSUBISHI |
|---|-------------------------------------|---|
| Material | SNCM | SCM equivalent |
| Strength N/mm ² (kgf/mm ²) | 1670 (approx.) (170 (approx.)) | 980 (approx.) (100 (approx.)) |
| Surface treatment | None | Black dye |
| Shape of head | Forged 12 point head | 12 point head |
| Tool (mm) | 12 Point BOX (12) | ← |
| Dia. Of axis | φ10.1 | φ9.4 |
| Thread | Form rolling at heat | Form rolling |
| Size | M11 x P1.25 | ← |
| Tightening | Elasticity, Reusable | Plasticity, In limit |
| Tightening method | Torque 112.8 N·m (11.5 kgf·m) | Low torque + Angle 20 N·m + 90deg + 90deg (2.0 kgf·m + 90deg + 90deg) |
| Lubrication | Engine oil | ← |

| Washer | HKS | MITSUBISHI |
|-------------------|-----------------------|---------------------------|
| Material | SCM | SC equivalent |
| Surface treatment | Nitriding | Black dye |
| Removal from bolt | Possible⇒ All washers | Not possible⇒ All washers |

Installation

1. Before installation

- Check the vehicle registration to make sure it has the engine that this product was designed for.
- Unpack and check the product contents to make sure no damage occurred during shipping.
- Make sure all required replacement parts and tools are available.
- Clean and blow air on the top surface of the cylinder head, bolt holes, head gasket and the product before installation.

2. Installation of the kit

(1) After removal of the cylinder head and head gasket, follow the instructions below.

- ① After removal of the head gasket, clean the deck surface between the head and block with a gasket removal tool. Be careful not to scratch the deck surface.
- ② As shown, measure the deck surfaces of the head (Fig. 1) and block (Fig. 2) with a feeler gauge to check for flatness.
- ③ If the measurement is out of specification, resurface the block and/or head.

Maximum warpage: less than 0.05mm

Maximum resurfacing amount: Less than 0.1mm (Surface density: More than 12.5S)

- ④ After resurfacing, remove burrs and clean the surfaces. Then, install the HKS Head Gasket.

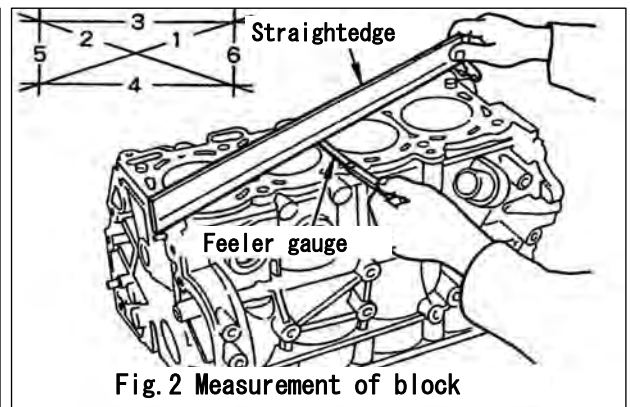
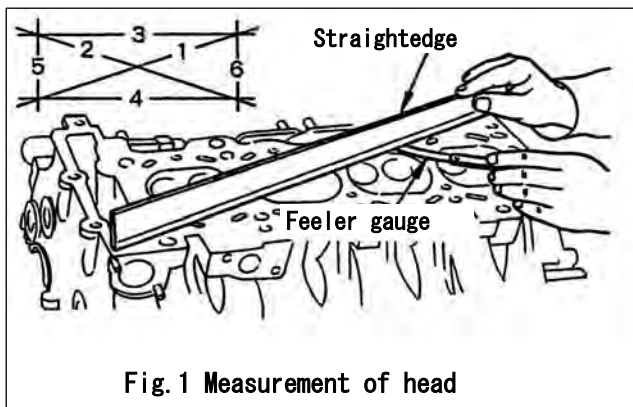

- (2) Apply engine oil to the seat surfaces of each bolt, washer and threads.

| | |
|---------------|--|
| Advice | <p>Do not use any other lubricants than engine oil.</p> <p>With molybdenum disulfide, copper grease, differential oil etc., which friction is different from engine oil, the designed torque specification may not be achieved.</p> |
|---------------|--|

(3) Install the washers with the chamfer side facing up. (Fig. 3)

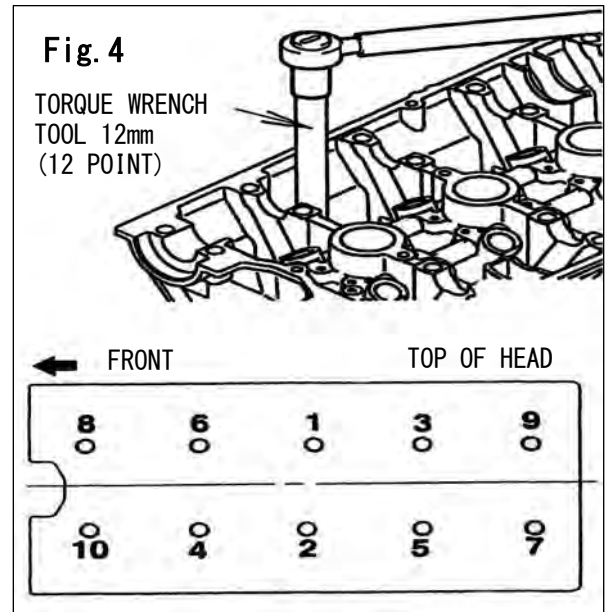
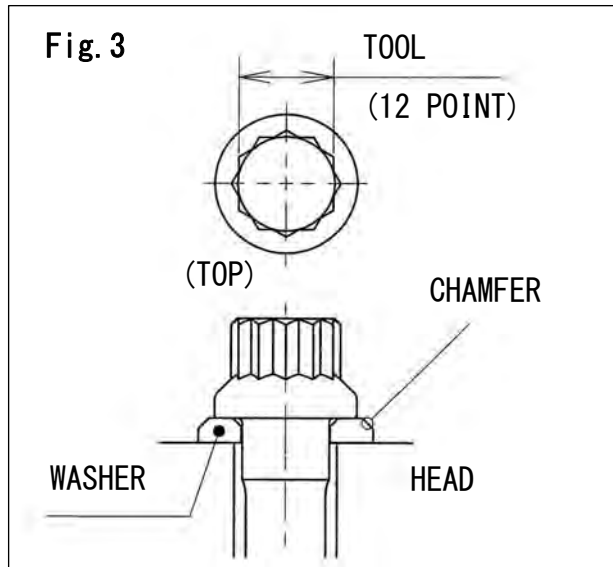

(4) Tighten the bolts with a torque wrench in the specified order in Fig. 4.

- ① Tighten in the specified order to **39.2 N·m (4.0 kgf·m)** of torque. Tighten again for confirmation in the same order.
- ② Tighten in the specified order to **78.5 N·m (8.0 kgf·m)** of torque.
- ③ Tighten in the specified order to **112.8 N·m (11.5 kgf·m)** of torque.
- ④ Fully loosen all bolts and tighten immediately to the **final torque of 112.8 N·m (11.5 kgf·m)**. Do this procedure for all 10 bolts in the specified order.

Maintenance

Make sure to properly maintain the operation of the vehicle.

- Maintenance of the vehicle is the driver's responsibility.
- Ask a professional installer for procedures not mentioned in this Users Manual.

Trouble shooting

- If any problems should occur, consult a professional installer.
- In case of any abnormal noise, smell or vibration, refer to the Mitsubishi Service Manual.



HKS Co., Ltd.

7181 Kitayama, Fujinomiya, Shizuoka
418-0192 JAPAN

<http://www.hks-power.co.jp/>

Published in December, 2009 by HKS Co., Ltd.

(Unauthorized reproduction is strictly prohibited.)