

BOLT-ON TURBO PRO KIT GTIII-RS

INSTALLATION MANUAL



Installation must be done by a professional.

Read this manual prior to the installation.

Always have access to this manual as well as a factory service manual.

NAME OF PRODUCT	BOLT-ON TURBO PRO KIT GTIII- RS
PURPOSE	AUTOMOBILE PARTS
PART NUMBER	11001-KT001
MANUAL NUMBER	E04211-T59071-00 Ver.3-3.05
VEHICLE	<ul style="list-style-type: none">• TOYOTA 86 (DBA-ZN6, 4BA-ZN6)• SUBARU BRZ (DBA-ZC6, 4BA-ZC6)
ENGINE	FA20
MODEL YEAR	<ul style="list-style-type: none">• TOYOTA 86: 2012/04~2021/10• SUBARU BRZ: 2012/03~2021/07
REMARKS	<p>【NOTE】</p> <ul style="list-style-type: none">• HKS is not responsible with the damage to the engine and/or other parts of a vehicle after installing this product.• An injector, fuel pump, engine management device, engine plug are not included in this product.• Modification of the radiator support, reinforcement, fan shroud, oil pan, etc. is required.• Check the spark plugs occasionally and replace them if necessary.• Upgrading the injectors and fuel pump is required.• Resetting by an engine management device must be done. Resetting of fuel and ignition must be done to avoid engine damage.• A boost controller such as HKS EVC is required when the boost pressure is changed.• Change the engine oil to the one with 40 or higher viscosity at high temperatures.• The boost pressure of the provided actuator is set to approximately 80-90 kPa.• When the engine output may exceed 257kw/350ps after installing this product, upgrading the engine parts is required.

Rev. Number	Date	Manual Number	Details
3-3.01	2018/03	E04211-T59010-00	1 st Edition
3-3.02	2018/06	E04211-T59011-00	2 nd Edition
3-3.03	2019/02	E04211-T59012-00	3 rd Edition
3-3.04	2022/12	E04211-T59070-00	4 th Edition
3-3.05	2023/11	E04211-T59071-00	5 th Edition

INDEX

NOTICE/ATTENTION	1
PARTS LIST	2
1. REMOVAL OF FACTORY PARTS	5
2. MODIFICATION OF FACTORY PARTS	8
3. INSTALLATION OF OIL INLET PARTS	13
4. INSTALLATION OF TURBOCHARGER BRACKET	15
5. INSTALLATION OF EXHAUST MANIFOLD	17
6. ASSEMBLY OF TURBOCHARGER	19
7. INSTALLATION OF TURBOCHARGER AND OIL RETURN HOSE	20
8. INSTALLATION OF EXTENSION PIPE	22
9. INSTALLATION OF TURBOCHARGER ACCESSORY PARTS	24
10. INSTALLATION OF AIR CLEANER AND SUCTION PIPE	26
11. INSTALLATION OF INTERCOOLER	28
12. INSTALLATION OF PIPING	30
13. REINSTALLATION OF FACTORY PARTS	32
14. CONFIRMATION AFTER INSTALLATION	33
15. TECHNICAL INFORMATION	34

NOTICE

Thank you for purchasing HKS BOLT-ON TURBO PRO KIT. This manual assumes that you have and know how to use the tools and equipment necessary to safely perform service operations on your vehicle. This manual assumes that you are familiar with typical automotive systems and basic service and repair procedures. Do not attempt to carry out the operations shown in this manual unless these assumptions are correct. Always have access to a factory repair manual. To avoid injury, follow the safety precautions contained in the factory repair manual.

ATTENTION

- This manual indicates items you need to pay attention to in order to install this product safely and lists precautions to avoid any possible damage and/or accidents.
- This product is an automobile part. Do not use for any other purposes.
- HKS will not be responsible for any damage caused by incorrect installation and/or use, or use after modification and/or dismantling of this product.
- This product was designed based on installation onto a specific factory vehicle.
- The specifications of this product are subject to change without notice.
- The instructions are subject to change without notice. Make sure to refer to the most recent instructions.

SAFETY PRECAUTIONS

The following precautions for use of this product are to prevent possible accidents and/or injuries and for proper use.



WARNING

Indicates risk of serious injury and/or possible death.



CAUTION

Indicates risk of damage to people or large-scale damage to property.
(Large-scale damage is the damage caused by a product defect.
Ex. Damage to a vehicle, burnout, etc.)

PARTS LIST**No.1**

No.	Description	QT	Remarks
1	Turbocharger Assembly	1	GTⅢ-RS
2	Exhaust Manifold	1	
3	Extension Pipe	1	
4	Suction Pipe	1	φ80
5	Intercooler Pipe	2	φ60
6	Chamber Pipe	1	φ70
7	Intercooler	1	
8	Turbocharger Bracket No.1	1	t = 9
9	Stepped Spacer	1	O.D. φ20
10	Spacer	1	O.D. φ20
11	Turbocharger Bracket No.2	1	Lower side of T/C
12	Turbocharger Bracket No.3	1	Side of T/C
13	Oil Inlet Hose	1	L=460mm
14	Oil Inlet Banjo	1	
15	Banjo Bolt M12 P1.25	1	
16	Copper Washer	2	12×17
17	T-fitting	1	PT1/8
18	Hexagon Fitting	1	
19	Oil Line Fitting	1	
20	Thermal Tube φ21	1	
21	Oil Outlet Pipe	1	
22	Gasket	1	For oil outlet pipe
23	Oil Return Pipe	1	For oil pan welding
24	Hose φ16 L=250mm	1	
25	Thermal Tube φ30 L=500mm	1	
26	Water Line Banjo No.1	1	
27	Water Line Banjo No.2	1	
28	Banjo Bolt M14	2	
29	Copper Washer	4	14×20
30	Hose φ8 L=1250mm	1	
31	Gasket	2	Exhaust manifold E/G side
32	Gasket	1	Exhaust manifold T/C side
33	Gasket	1	Extension T/C side
34	Gasket	1	Extension Exhaust side
35	Intercooler Bracket No.1	1	Left
36	Intercooler Bracket No.2	1	Right
37	Intercooler Bracket No.3	1	Lower
38	Intercooler Bracket No.4	1	Upper

PARTS LIST**No.2**

No.	Description	QT	Remarks
39	Spacer	2	O.D. φ16
40	Extension Bracket	1	
41	Air Cleaner	1	φ200-80
42	Air Cleaner Bracket No.1	1	
43	Air Cleaner Bracket No.2	1	
44	Silicone Hose φ80	2	
45	Silicone Hose φ60	4	
46	Silicone Hose φ70	1	
47	Hose Band #52	4	#52
48	Hose Band #48	2	#48
49	Hose Band #40	10	#40
50	Hose Band #28	2	#28
51	Hose φ12 L=200mm	1	
52	Joint Pipe	1	φ12
53	Insulator	1	For turbocharger
54	Insulator φ50 L=100mm	1	For exhaust manifold
55	Insulator φ60 L=120mm	1	For extension
56	Flange Bolt M10 L50 7-mark	2	
57	Hexagon Bolt M8 L15	8	
58	Flat Washer M8	8	
59	Hexagon Bolt M10 L40	2	
60	Flat Washer M10	4	
61	Hexagon Nut M10	2	
62	Stud Bolt M8 13-9-16	4	
63	Stud Bolt M8 7-10-14	5	
64	Lock Nut M8	9	
65	Flange Bolt M8 L10	1	
66	Flange Bolt M8 L15	5	
67	Flange Nut M8	2	
68	Flange Bolt M6 L35	2	
69	Flange Nut M6	5	
70	Flange Bolt M6 L15	5	
71	Flange Bolt M6 L10	2	
72	Hose Clamp Mark 230	2	
73	Hose Clamp Mark 180	3	
74	Hose Clamp Mark 138	1	
75	Hose Clamp Mark 130	3	
76	Hose Clamp Mark 115	3	

PARTS LIST**No.3**

No.	Description	QT	Remarks
77	Rubber Cap ϕ 16	1	
78	Button Bolt M4 L10	2	
79	Tie Wrap L	10	
80	Tie Wrap M	10	
81	Sponge Sheet 50mm \times 50mm	5	
82	Insulator Sheet 70mm \times 1000mm	1	
83	Insulator Sheet 300mm \times 300mm	2	
84	Installation Manual	1	The book
85	Instruction Manual	1	

1. REMOVAL OF FACTORY PARTS

Use this instruction manual and the manufacturer's service manual as a reference.

PARTS LIST

The parts list number shown in the table on the right corresponds to the number of the parts list on page 2-4.	No.	Description	Qt
		P77	Rubber Cap φ16

- (1) Disconnect the negative cable from the battery.
- (2) Remove the engine under cover. (The removed cover will be reinstalled later.)
- (3) Remove ①side-mounted turn signal from both sides. (The removed signals will be reinstalled later.)
- (4) Remove ②front bumper. (The removed bumper will be reinstalled later.)
- (5) Drain the engine oil and coolant.

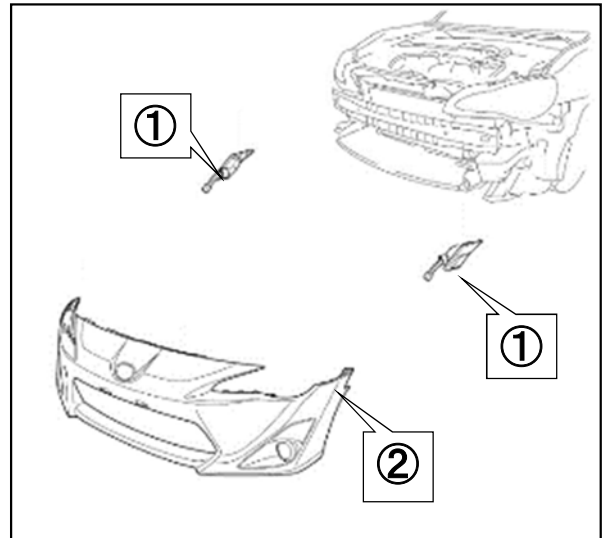

- (6) Remove ③front bumper energy absorber. (The removed absorber will be modified and reinstalled later.)
- (7) Remove ④front bumper reinforcement plate from both sides
- (8) Remove ⑤radiator cover plate.
- (9) Remove ⑥horn. (The removed horn will be reinstalled later.)
- (10) Remove ⑦front bumper cover LWR. (The removed cover will be reinstalled later.)
- (11) Remove ⑧front bumper bracket; then remove the front bumper support. (The removed bracket will be reinstalled later. The removed support will be modified and reinstalled later.)

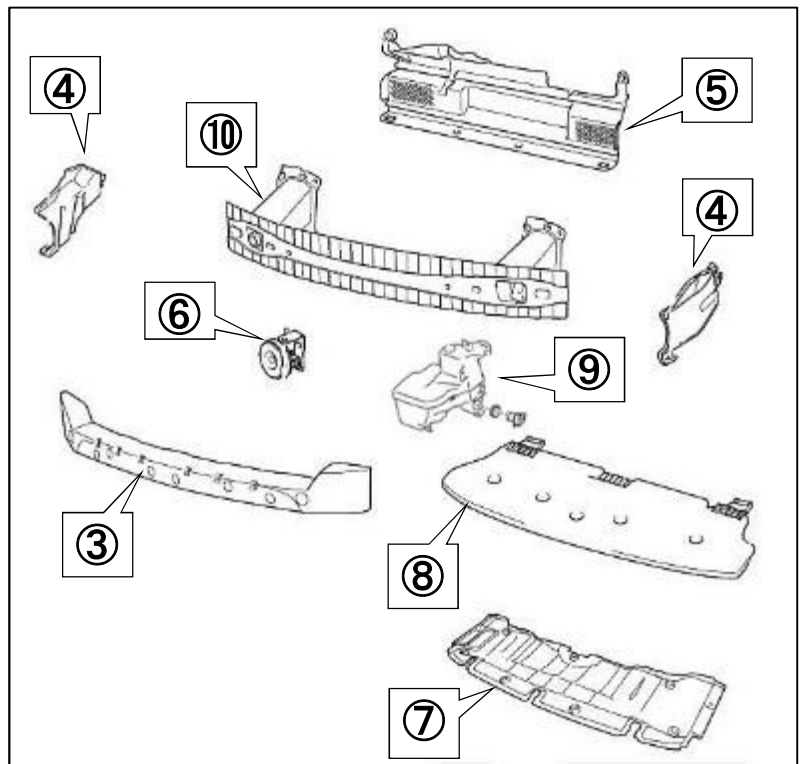

- (12) Shift ⑨washer tank and remove ⑩reinforcement. (The removed reinforcement will be modified and reinstalled later.)

(13) Remove ⑪ air cleaner case.

(14) Remove ⑫ air cleaner duct.

(15) Remove ⑬ hood lock from the radiator support. (The removed lock will be reinstalled later.)

(16) Remove ⑭ radiator support. (The removed support will be reinstalled later.)

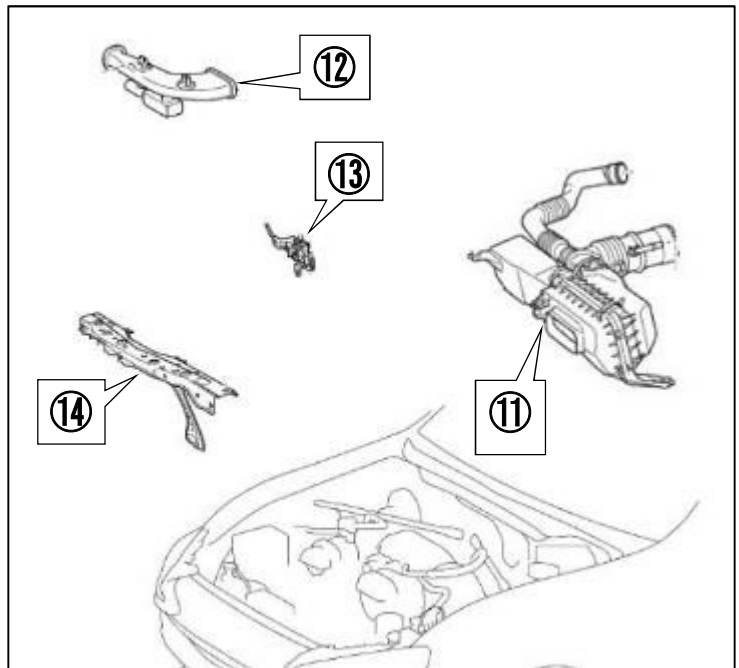

(17) Remove ⑮ air cleaner duct, ⑯ chamber, and ⑰ hose.

(18) Install the Rubber Cap ϕ 16 to the hole ⑰ hose was removed from.

- P77: Rubber Cap ϕ 16 \times 1

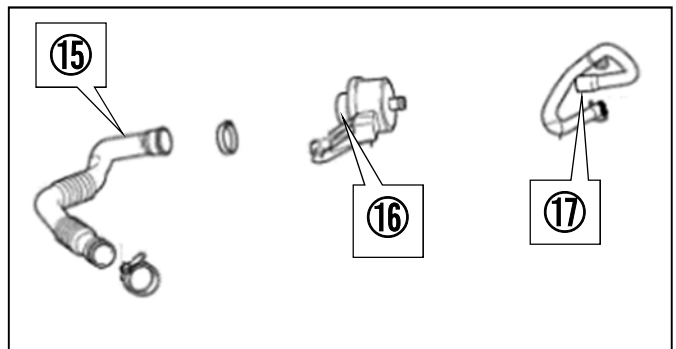

(19) Remove ⑱ air cleaner case bracket. The removed bolt will be reused later.

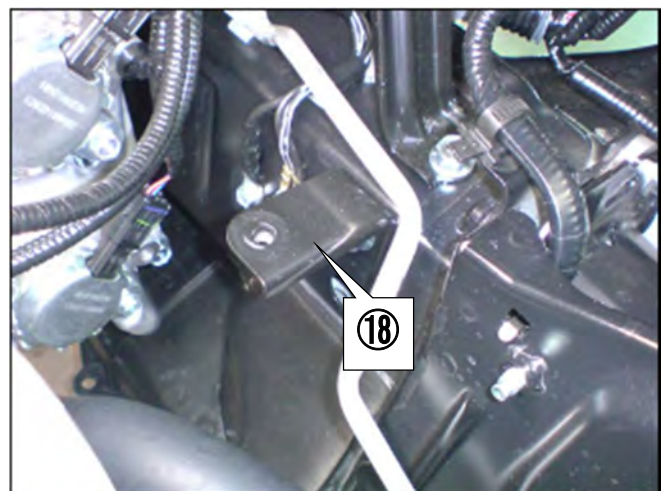

(20) Remove ⑱ fan shroud. (The removed shroud will be modified and reinstalled later.)

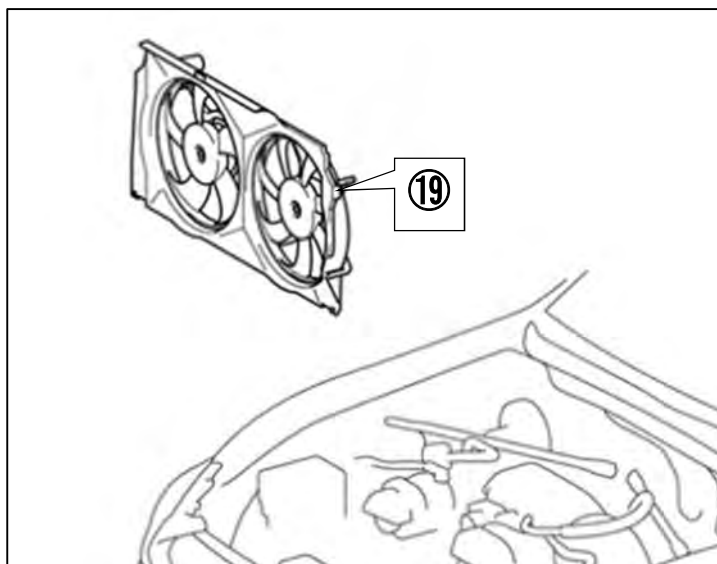

(21) Remove ⑳ exhaust manifold. (The removed nut will be reused later.)

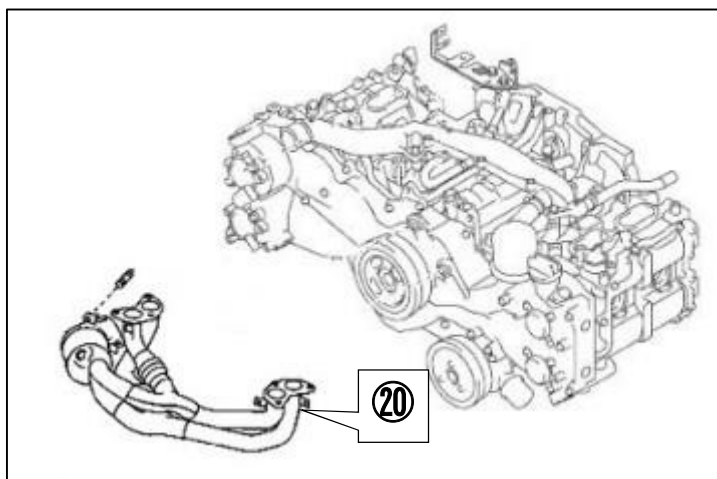

(22) Remove ㉑ oil pan. (The removed pan will be modified and reinstalled later.)
The removed bolt and seals will be reused later.

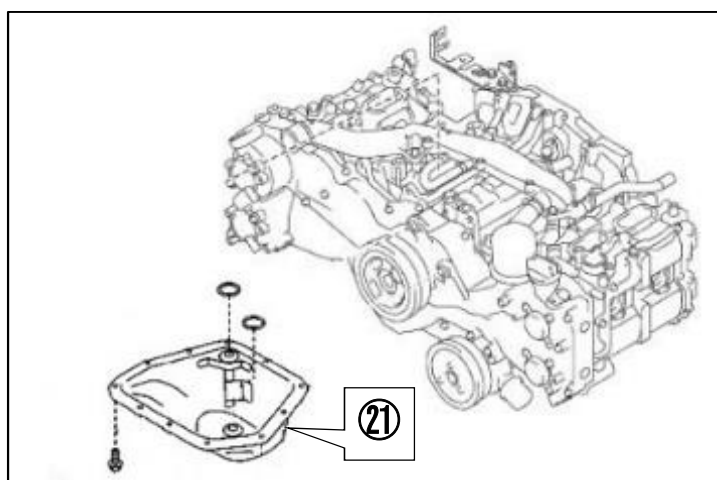

2. MODIFICATION OF FACTORY PARTS

PARTS LIST

No.	Description	Qt
P2	Exhaust Manifold	1
P23	Oil Return Pipe	1
P31	Gasket	2
P69	Flange Nut M6	1
P70	Flange Bolt M6 L15	1
P73	Hose Clamp Mark 180	1
P74	Hose Clamp Mark 138	1
P75	Hose Clamp Mark 130	1
P76	Hose Clamp Mark 115	3
P80	Tie Wrap M	3
P83	Insulator Sheet 300mm×300mm	1

(1) Cut off the shaded portion of the reinforcement as shown below:

NOTE

Modify the reinforcement to avoid unnecessary contact with the intercooler.

Mark the center position of the reinforcement. Cut the reinforcement referring to the photo on the right.

Make sure to leave the holes to install the intercooler bracket.

After cutting off the shaded portions, remove burr and apply a rust prevention treatment.

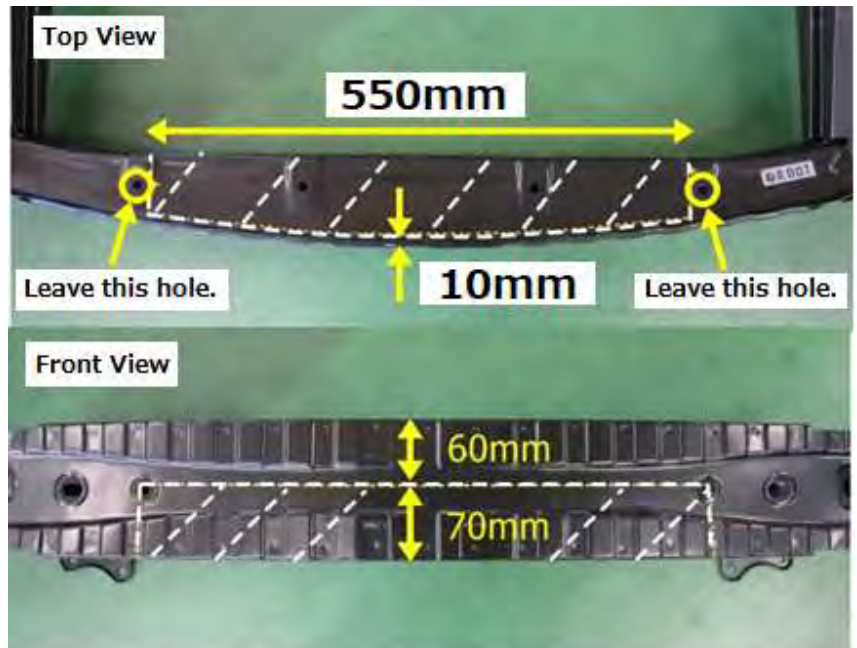

(2) Install the Flange Bolt M6 L15 from the back of the right side hole in the reinforcement. Install the Flange Nut M6 to the bolt.

- P69: Flange Nut M6 x 1
- P70: Flange Bolt M6 L15 x 1

NOTE

These bolt and nut are to install a horn. Use a magnet hand or a similar tool for easy installation.

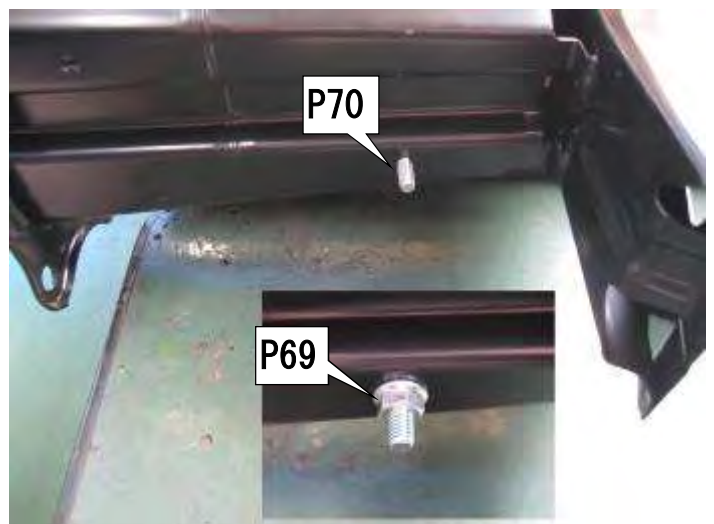

- (3) Cut off the shaded portion of the front bumper energy absorber as shown in the photo on the right.

NOTE

Cut off the portion along the rib on the back.

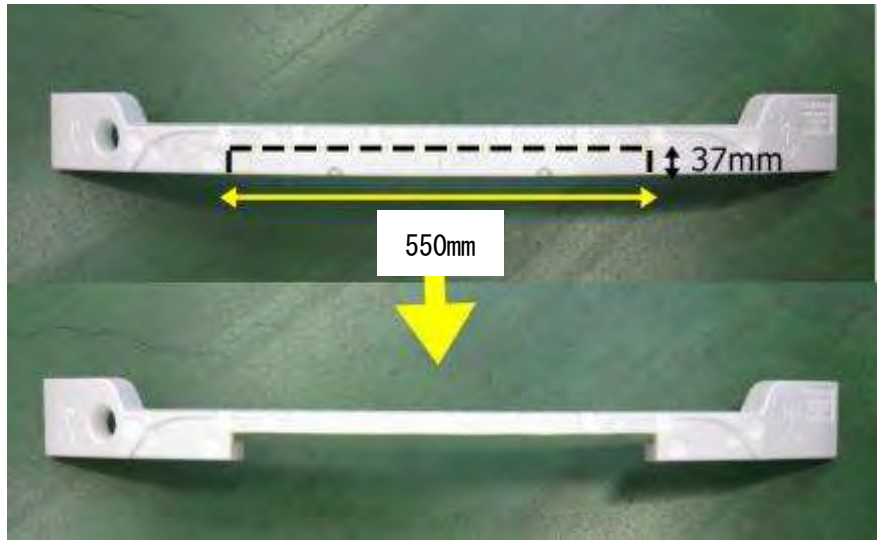

- (4) Modify the front bumper bracket as shown in the photo shown on the right.

NOTE

This modification is to secure the intercooler bracket.

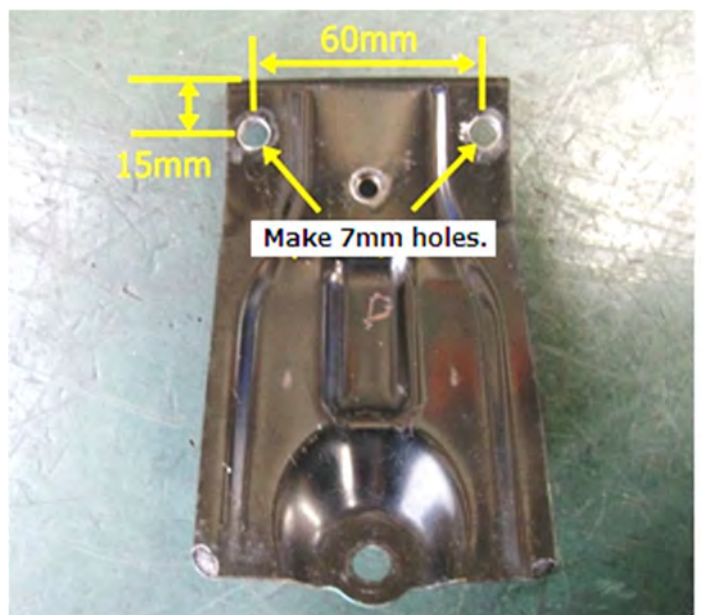

- (5) Cut the radiator support as shown in the photo on the right.

NOTE

This modification is to avoid unnecessary contact with the intercooler pipe.

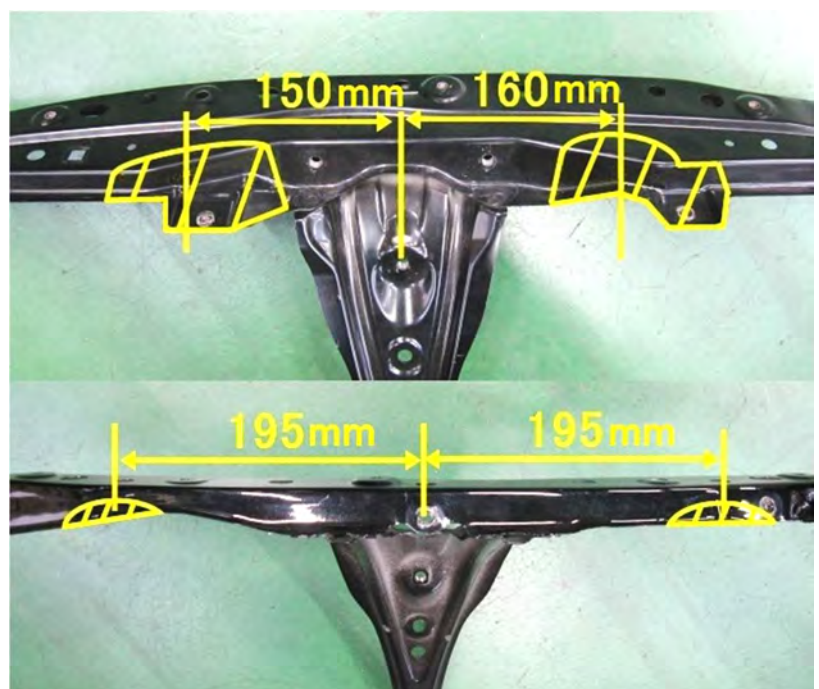

(6) Cut the fan shroud as shown in the photos on the right side.

NOTE

This modification is to avoid unnecessary contact with the air cleaner and piping.

Install the modified fan shroud to the vehicle.

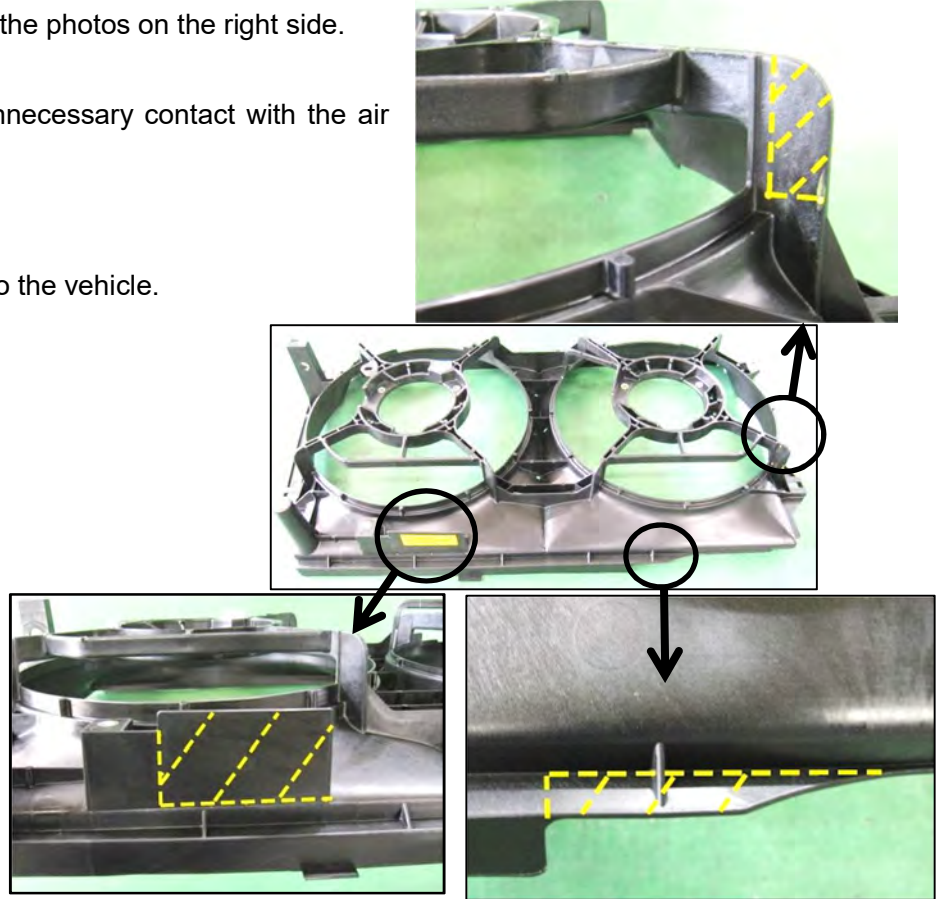

(7) Cut the Insulator Sheet 300 x 300 to an appropriate size and wrap the wire with a cut sheet. After wrapping the wire, wind the wrapped wire to prevent the sheet from peeling off from the wire as shown in the photo on the right.

- P83: Insulator Sheet 300mm×300mm x 1

(8) Change the electric fan wiring as shown in the photo on the right. Secure the wire using three Tie Wrap M.

- P80: Tie Wrap M x 3

NOTE

Wiring from the center of the fan shroud should be placed to the back of the radiator support that will be installed later.

(9) Remove the oil pan from the vehicle.

(10) Drill a 17mm hole in the position indicated in the photo on the right.

NOTE

Make sure to measure from the flange edge by a ruler.

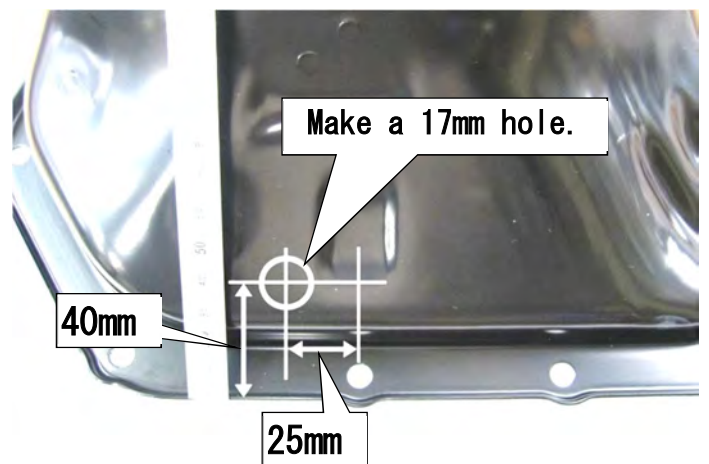
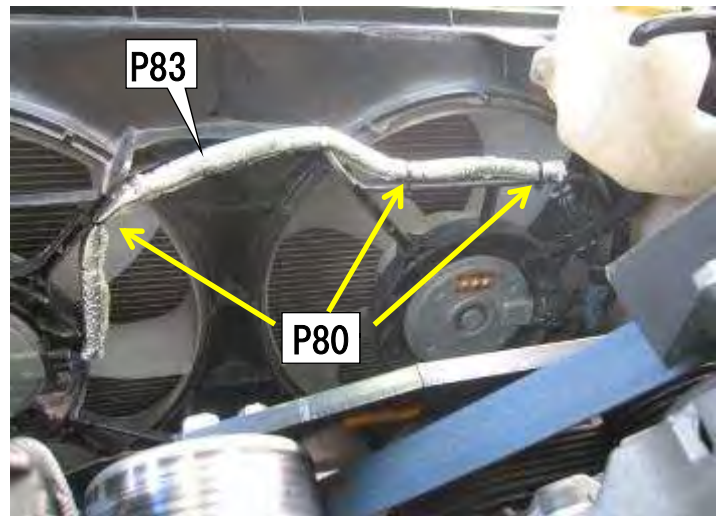

(11) Temporarily reinstall the oil pan, and temporarily install the Exhaust Manifold using the provided Gaskets.

- P2: Exhaust Manifold x 1
- P31: Gasket x 1

(12) Determine the installation position of the Oil Return Pipe. Mark the position or temporarily install the pipe.

- P23: Oil Return Pipe x 1

NOTE

Make sure the clearance between the exhaust manifold and Oil Return Pipe is at least 15mm. The clearance between the V-belt and pipe should be approximately 20mm, and approximately 60mm between the bolt. Please refer to those photos on the right.

Make sure to insert the Oil Return Pipe to the oil pan until the pipe end contacts the stopper.

(13) Remove the oil pan. Weld the Oil Return Pipe to the oil pan.

NOTE

Weld the pipe gradually and make sure the clearance between parts during welding.

Remove paint on the welding part of the oil pan using a sand-paper before welding.

Carefully check the welding seam for leads.

(14) Apply a rust prevention treatment to the weld zone. After the treatment is applied and the applied zone becomes dry, clean the parts.

NOTE

Make sure to remove all foreign objects such as burr, chip, etc. to prevent engine damage.

(15) Clean the installation surface of the oil pan and engine using a scraper or a similar tool and remove oil from the surfaces. Install the oil pan using a liquid gasket 1217G.

NOTE

Reuse the factory bolt and seals.

(16) Remove the Exhaust Manifold.

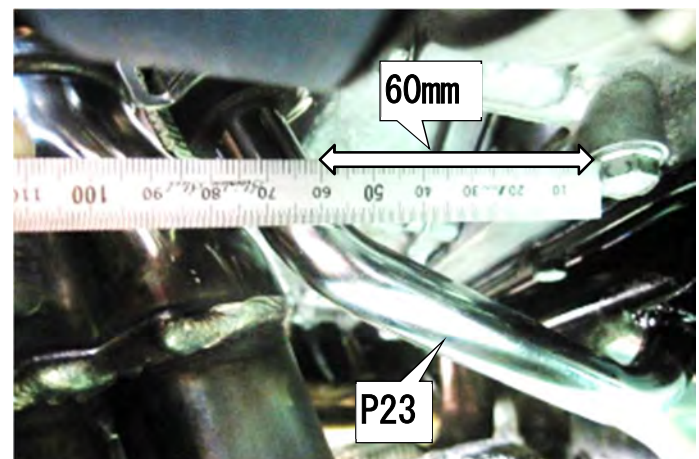
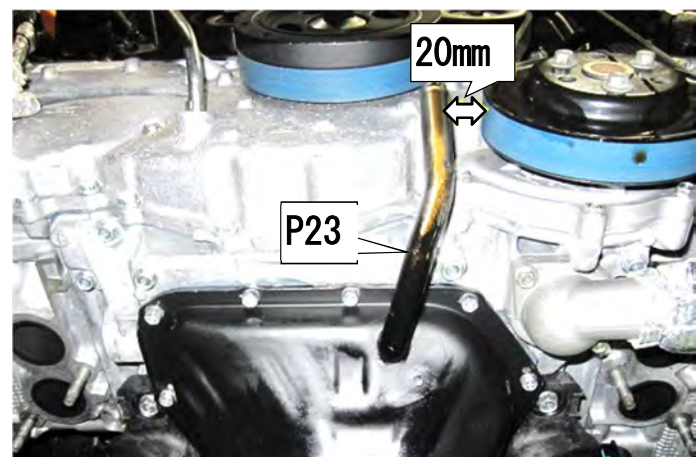
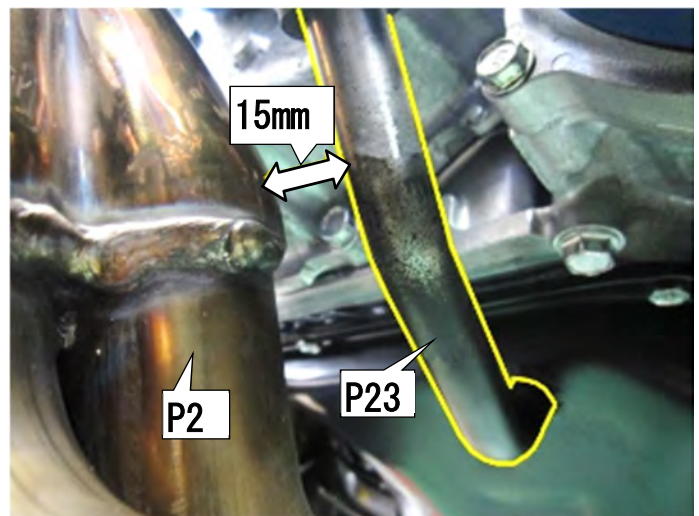
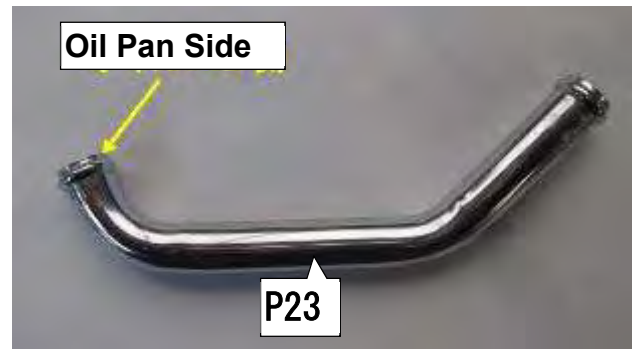

(17) Remove the installation bolt from the A/C compressor.
Move the compressor slightly so there is adequate space for installation function under the intake manifold.

NOTE

Do not disconnect the piping.

(18) Remove the installation bolt from the throttle body. Move the throttle body slightly so there is adequate space for installation function under the intake manifold.

NOTE

Do not disconnect the water piping.

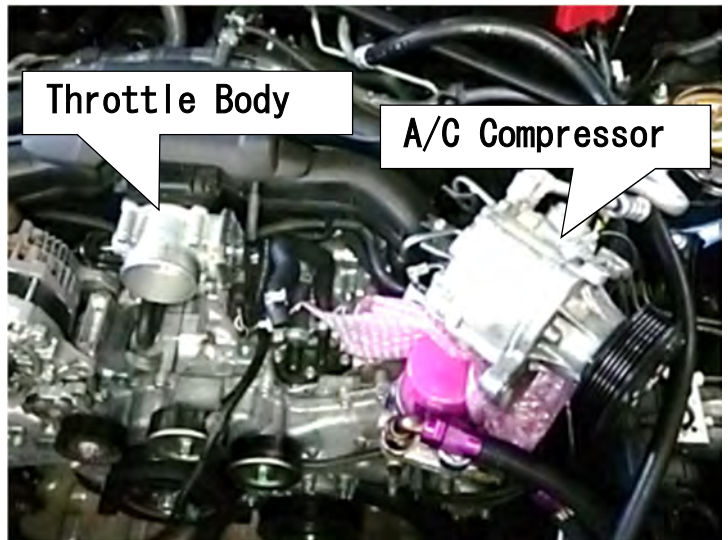

(19) Remove the canister purge solenoid from the intake manifold.
Install the Hose Clamps as shown in the diagram on the right.

- P75: Hose Clamp Mark 130 x 1
- P76: Hose Clamp Mark 115 x 3

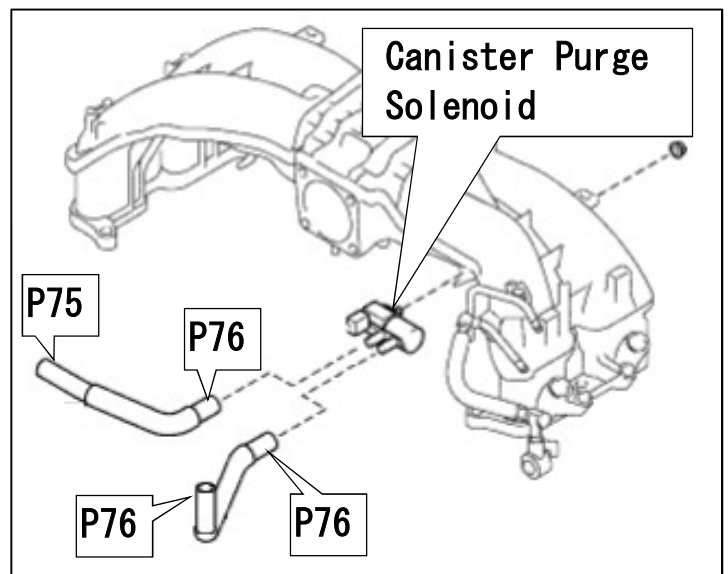

(20) Reinstall the canister purge solenoid.
Place the throttle body and A/C compressor back in place.

(21) Install the Hose Clamps to the blow-by hose.

- P73: Hose Clamp Mark 180 x 1
- P74: Hose Clamp Mark 138 x 1

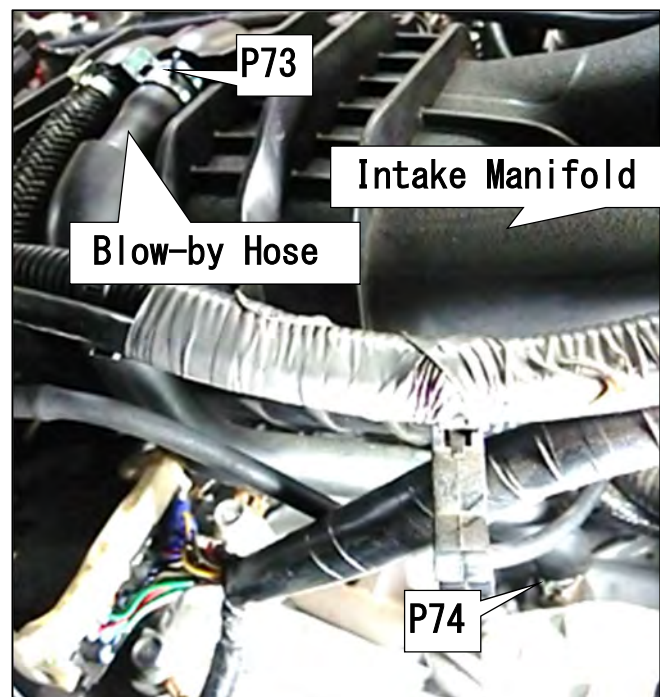

3. INSTALLATION OF OIL INLET PARTS

※Air-blow each part before installation to prevent the entry of foreign debris.

PARTS LIST

No.	Description	Qt
P13	Oil Inlet Hose	1
P14	Oil Inlet Banjo	1
P17	T-fitting	1
P18	Hexagon Fitting	1
P19	Oil Line Fitting	1
P20	Thermal Tube φ21	1

(1) Remove the oil pressure switch from the engine block.

(2) Install the Hexagon Fitting and Oil Line Fitting to the T-fitting. Apply the ThreeBond TB1324 thinly to the PT thread.

- P17: T-fitting x 1
- P18: Hexagon Fitting x 1
- P19: Oil Line Fitting x 1

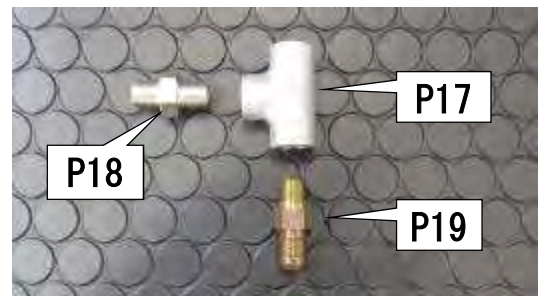

NOTE

Make sure not to overtighten the PT thread to prevent damage to other parts of the vehicle.

Apply only minimum required amount of ThreeBond TB1324 so it does not run off to the oil flow line.

(3) Install the assembled fittings to the engine as shown in the photo on the right. Apply the ThreeBond TB1324 thinly to the PT thread.

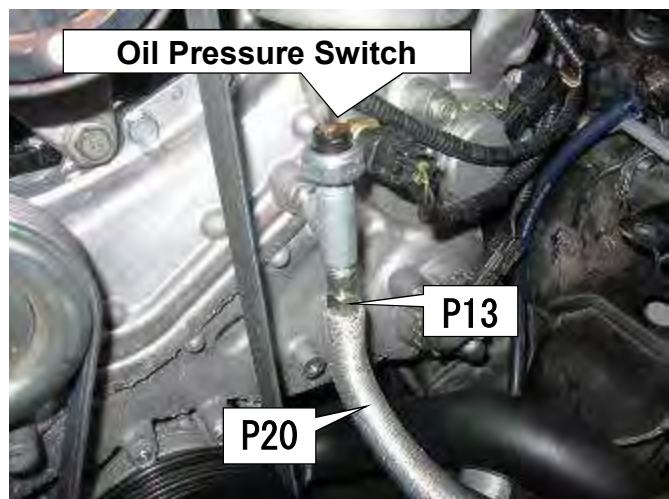

(4) Install the removed oil pressure switch to the engine as shown in the photo on the right. Apply the ThreeBond TB1324 to the PT thread.

(5) Install the Oil Inlet Hose.

- P13: Oil Inlet Hose x 1

(6) Cut the provided Thermal Tube $\phi 21$ to 450mm in length. Cover the hose with the cut tube.

- P20: Thermal Tube $\phi 21 \times 1$

(7) Temporarily install the Oil Inlet Banjo.

- P14: Oil Inlet Banjo x 1

NOTE

The inlet banjo will be tightened completely after the turbocharger is installed.

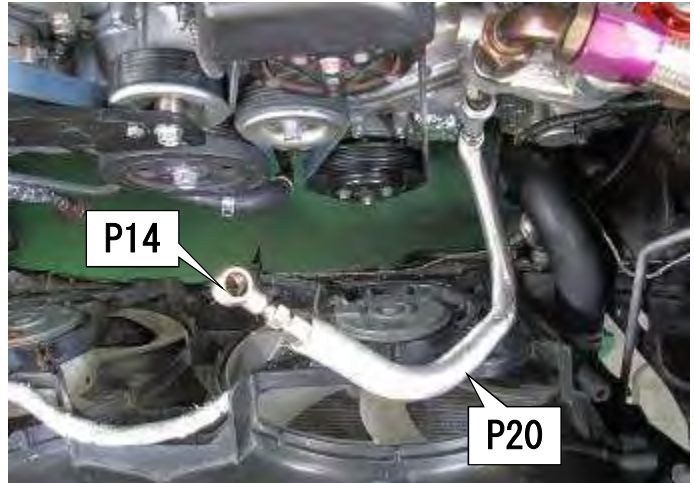



Caution

- When assembling the oil line, do not use a seal tape. Make sure to use only minimum required amount of liquid gasket to prevent damage to the turbocharger assembly.
- Make sure to secure the oil inlet hose without excessive force on the caulking section of the oil inlet hose and bending the hose too tight. If neglected, excessive stress may be applied to the hoses by engine vibration and such which may result in leakage of oil causing vehicles fire in the worst case.

4. INSTALLATION OF TURBOCHARGER BRACKET

PARTS LIST

		No.	Description	Qt
	P8	Turbocharger Bracket No.1	1	
	P9	Stepped Spacer $\phi 20$	1	
 	P10	Spacer $\phi 20$	1	
	P56	Flange Bolt M10 L50 7-mark	2	
	P71	Flange Bolt M6 L10	1	

- (1) Place a tool on the belt tensioner bolt. Loosen the belt as shown in the diagram on the right and secure it with a 3mm hexagonal wrench or a similar tool.

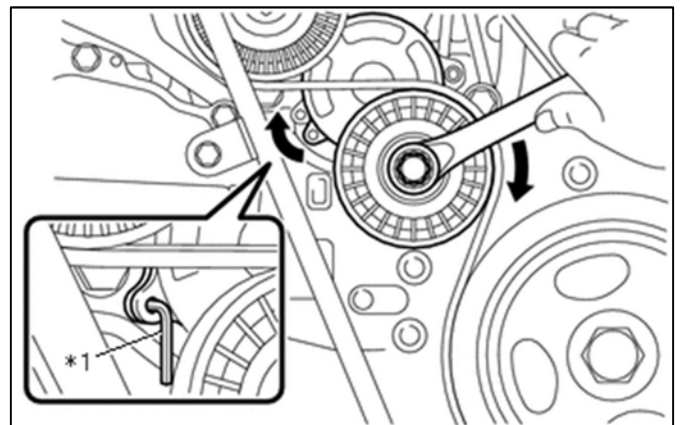

- (2) Remove the idler pulley No.1 as shown in the diagram on the right. The removed idler pulley cover (washer) will be reused later.

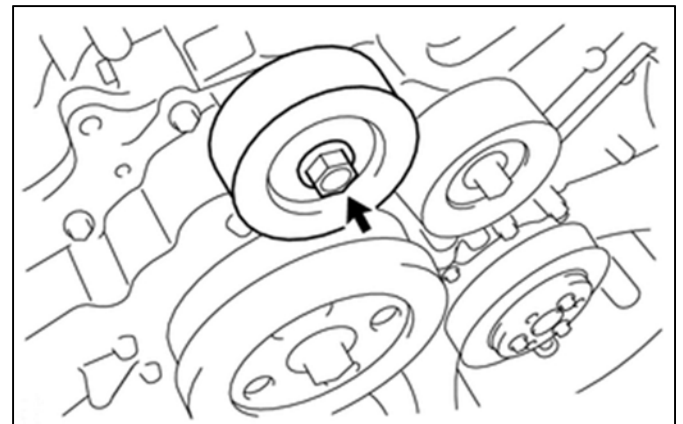

- (3) Remove the idler pulley No.2 as shown in the diagram on the right. The removed idler pulley cover (washer) will be reused later.

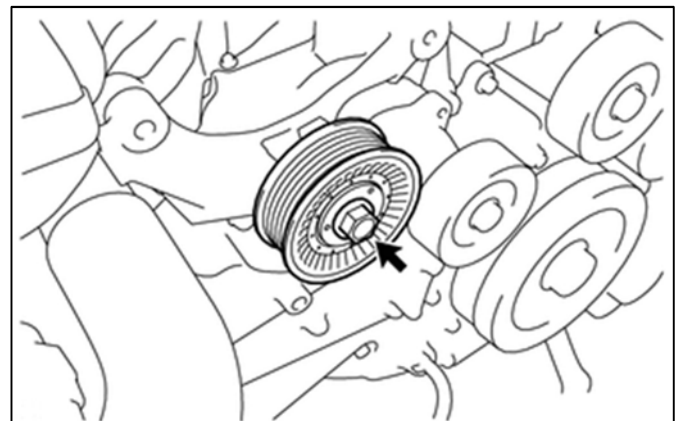

(4) Install the Turbocharger Bracket No.1, Stepped Spacer ϕ 20, Spacer ϕ 20, removed idler pulley cover, and idler pulley using the provided Flange Bolt M10 L50 7-mark.

- P8: Turbocharger Bracket No.1 x 1
- P9: Stepped Spacer ϕ 20 x 1
- P10: Spacer ϕ 20 x 1
- P56: Flange Bolt M10 L50 7-mark x 1

NOTE

Make sure to install the Stepped Spacer in a correct direction.

● Tightening Torque : N · m (kgf·m)

M10 : T=36 (3.67)

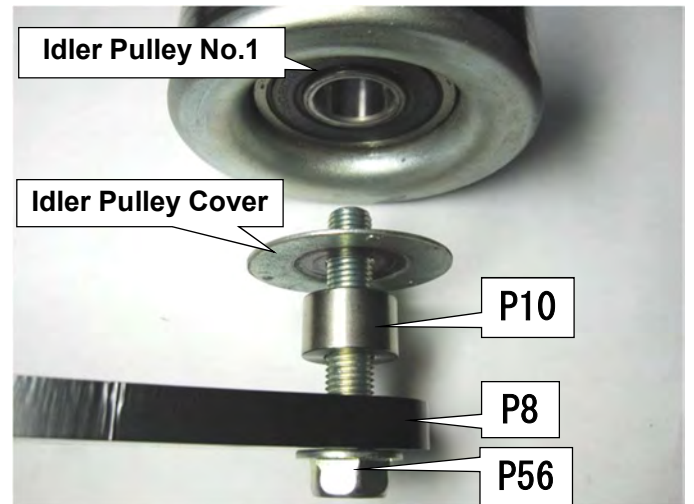
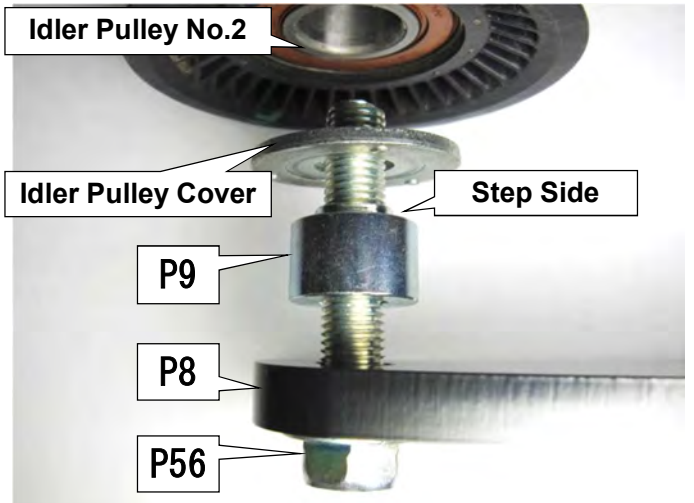

(5) Temporarily install the Flange Bolt M6 L10 as shown in the photo on the right.

- P71: Flange Bolt M6 L10 x 1

NOTE

This bolt is to install the insulator.
The bolt is installed here for easier installation of the insulator.

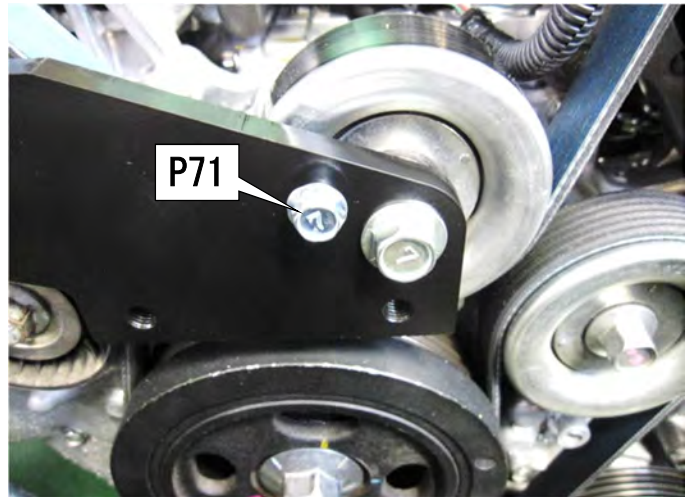

(6) Make sure the belt is placed on all pulleys. Remove the 3mm hexagonal wrench or a similar tool securing the belt. Make sure a proper tension is applied to the belt.



5. INSTALLATION OF EXHAUST MANIFOLD

PARTS LIST

No.	Description	Qt
P2	Exhaust Manifold	1
P11	Turbocharger Bracket No.2	1
P31	Gasket	2
P40	Extension Bracket	1
P50	Hose Band #28	2
P54	Insulator $\phi 50$ L=100mm	1
P57	Hexagon Bolt M8 L15	4
P58	Flat Washer M8	4
P62	Stud Bolt M8 13-9-16	4
P83	Insulator Sheet 300mm \times 300mm	1

(1) Install the Stud Bolt M8 13-9-16 to the Exhaust Manifold.

- P62: Stud Bolt M8 13-9-16 x 4

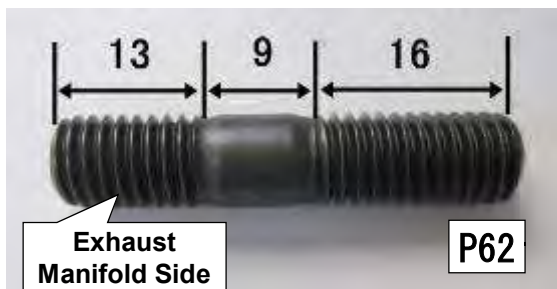

(2) Install the Insulator $\phi 50$ L=100 to the Exhaust Manifold using the provided Hose Band #28 as shown in the photos on the right.

- P50: Hose Band #28 x 2
- P54: Insulator $\phi 50$ L=100mm x 1

NOTE

Place the insulator toward the engine side.
Install the hose band over the SUS mesh.

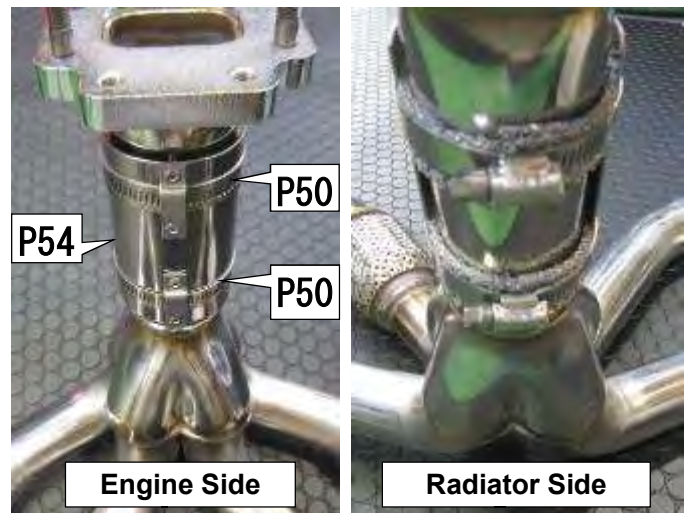

- (3) Cut the Insulator Sheet to an appropriate size as shown in the photo on the right. Wrap the radiator hose with the Insulator Sheet and secure the sheet with a wire.

- P83: Insulator Sheet 300mm×300mm x 1

NOTE

Insulate the other parts around the exhaust manifold.



- (4) Temporarily install the Exhaust Manifold using the provided Gasket and factory nut. For the right side flange, install the Extension Bracket together as shown in the photo on the right.

- P2: Exhaust Manifold x 1
- P31: Gasket x 2
- P40: Extension Bracket x 1

NOTE

For easier positioning of the extension bracket, temporarily install the extension bracket after installing the extension.

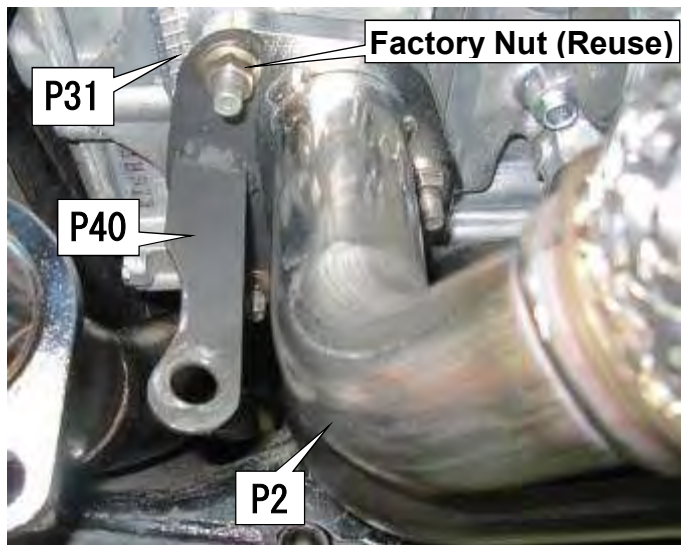

- (5) Temporarily install the Turbocharger Bracket No.2 to the flange on the turbocharger side.

- P11: Turbocharger Bracket No.2 x 1
- P57: Hexagon Bolt M8 L15 x 4
- P58: Flat Washer M8 x 4

NOTE

Do not use the flange bolt here since the bracket seat surface is narrow.

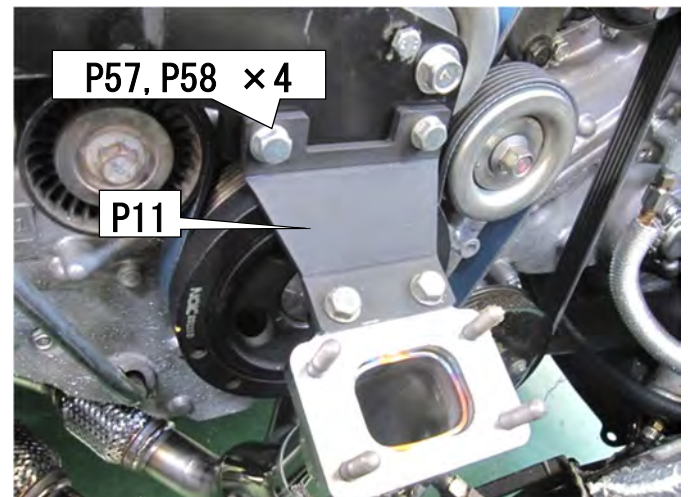

- (6) Determine the installation position of the Exhaust Manifold; then tighten the Turbocharger Bracket No.2 completely.

6. ASSEMBLY OF TURBOCHARGER

※Air-blow each part before installation to prevent the entry of foreign debris.

PARTS LIST



No.	Description	Qt
P1	Turbocharger Assembly	1
P21	Oil Outlet Pipe	1
P22	Gasket	1
P63	Stud Bolt M8 7-10-14	5
P70	Flange Bolt M6 L15	2

(1) Install the Oil Outlet Pipe to the Turbocharger using the provided Gasket as shown in the photo on the right.

- P1: Turbocharger Assembly x 1
- P21: Oil Outlet Pipe x 1
- P22: Gasket x 1
- P70: Flange Bolt M6 L15 x 2

NOTE

Make sure to install the oil outlet pipe in a correct direction.

- Tightening Torque : N · m (kgf·m)
M6 : T=8.5~10 (0.8~1.0)

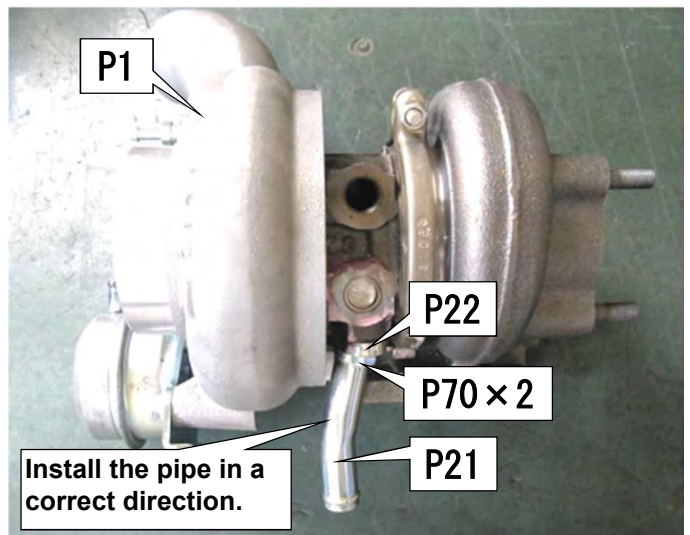

(2) Install the Stud Bolt M8 to the Turbocharger Assembly.

- P63: Stud Bolt M8 7-10-14 x 5

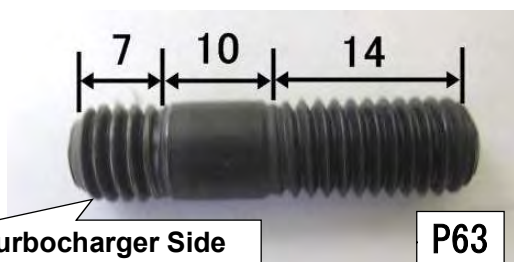

7. INSTALLATION OF TURBOCHARGER and OIL RETURN HOSE

※Air-blow each part before installation to prevent the entry of foreign debris.

PARTS LIST			
No.	Description	Qt	
P24	Hose ϕ 16 L=250mm	1	
P25	Thermal Tube ϕ 30 L=500mm	1	
P32	Gasket	1	
P64	Lock Nut M8	4	
P72	Hose Clamp Mark 230	2	

(1) Cut the provided Hose ϕ 16 to 195mm in length.

- P24: Hose ϕ 16 L=250mm x 1

(2) Install the cut Hose to the Oil Return Pipe installed in 2-(16). Secure the hose with the provided Hose Clamp Mark 230.

- P72: Hose Clamp Mark 230 x 2

NOTE

Do not completely tighten the hose clamp on the turbocharger side.

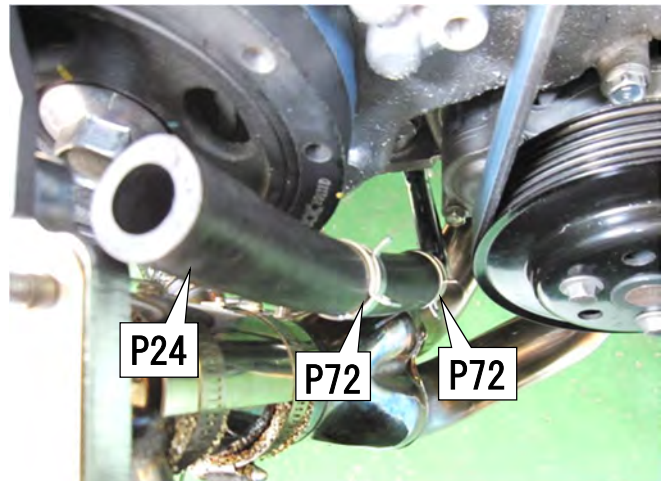

(3) Install the Turbocharger Assembly to the Exhaust Manifold using the provided Gasket and Lock Nut M8 as shown in the photo on the right.

- P32: Gasket x 1
- P64: Lock Nut M8 x 4

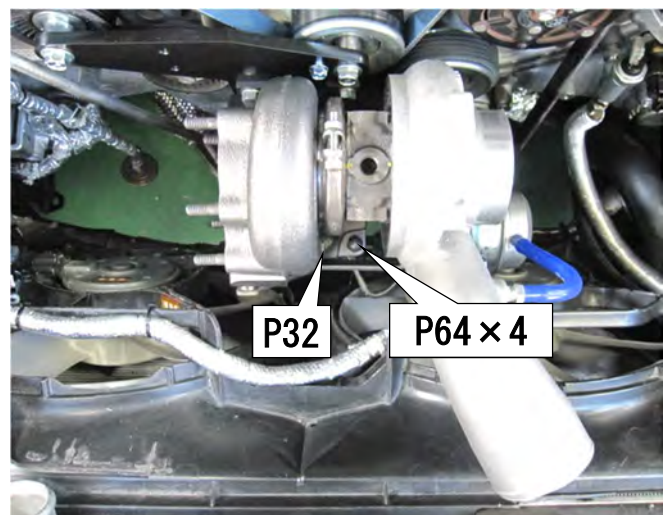

- (4) Connect the Hose from the Oil Return Pipe to the Oil Outlet Pipe from the Turbocharger Assembly. Secure the hose with the provided Hose Clamp Mark 230.

NOTE

Make sure the hose does not come in contact with the exhaust manifold, pulley, and belt.

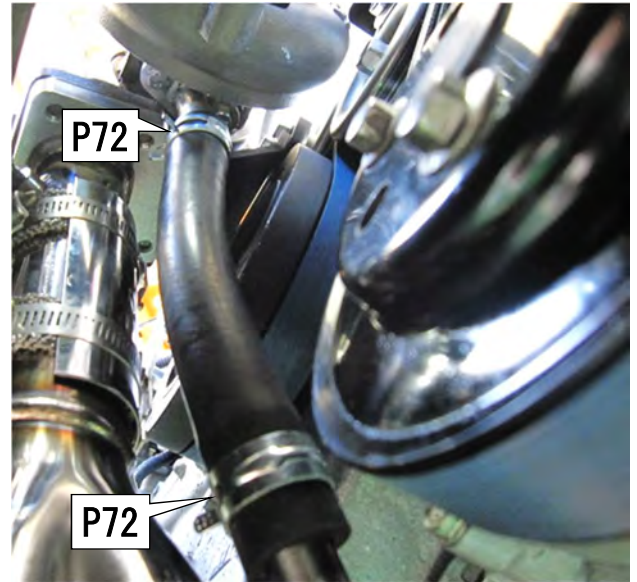

- (5) Cut the provided Thermal Tube $\phi 30$ to 195mm. Make a relief cut for the hose clamp's exposed tabs.

- P25: Thermal Tube $\phi 30$ L=500mm x 1

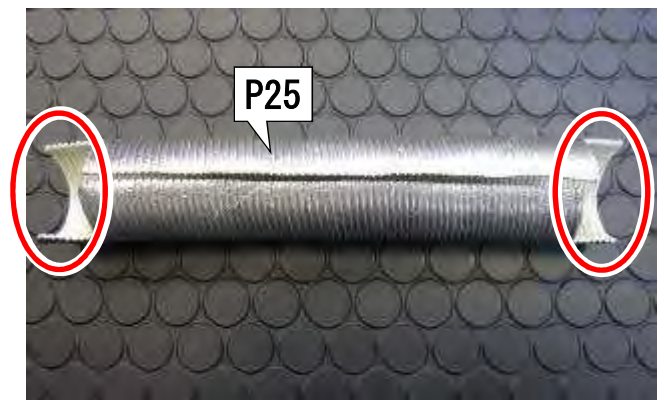

- (6) Cover the hose with the Thermal Tube modified in (5). Secure the covered hose with a wire.



NOTE

Make sure the hose does not come in contact with the exhaust manifold, pulley, and belt.



8. INSTALLATION OF EXTENSION PIPE

PARTS LIST

		No.	Description	Qt
		P3	Extension Pipe	1
		P12	Turbocharger Bracket No.3	1
		P33	Gasket	1
		P34	Gasket	1
		P49	Hose Band #40	2
		P55	Insulator $\phi 60$ L=120mm	1
		P57	Hexagon Bolt M8 L15	4
		P58	Flat Washer M8	4
		P59	Hexagon Bolt M10 L40	2
		P60	Flat Washer M10	4
		P61	Hexagon Nut M10	2
		P64	Lock Nut M8	5
		P71	Flange Bolt M6 L10	1
		P83	Insulator Sheet 300mm×300mm	1

- (1) Cut the provided Insulator Sheet to an appropriate size. Wrap the air-fuel ratio sensor wire with the sheet and secure it with a wire.

- P83: Insulator Sheet 300mm×300mm x 1

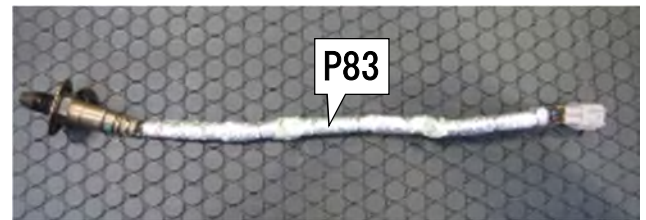

- (2) Cut the provided Insulator Sheet to an appropriate size. Wrap the camshaft position sensor wire with the sheet and secure it with a wire.

- P83: Insulator Sheet 300mm×300mm x 1

NOTE

Affix the insulator sheet to other parts around the extension. Insulator other wires or resin parts if necessary.



(3) Install the provided Insulator $\phi 60$ to the Extension as shown in the photo on the right, and secure it with the provided Hose Band #40.

- P3: Extension Pipe x 1
- P49: Hose Band #40 x 2
- P55: Insulator $\phi 60$ L=120mm x 1

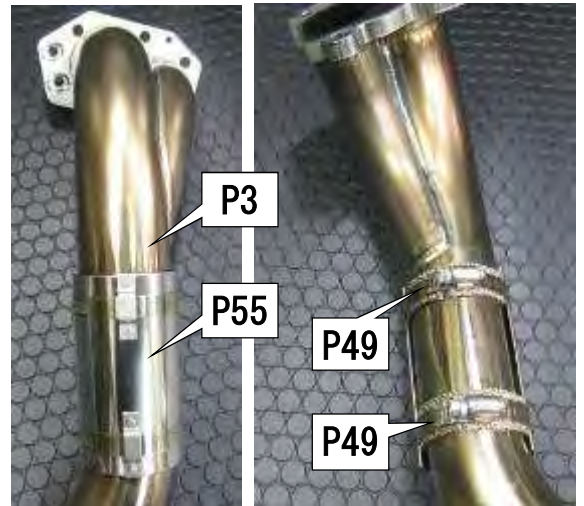

(4) Install the Extension with the Insulator to the Turbocharger using the provided Gasket, and tighten them with the provided Lock Nut M8.

- P33: Gasket x 1
- P64: Lock Nut M8 x 5

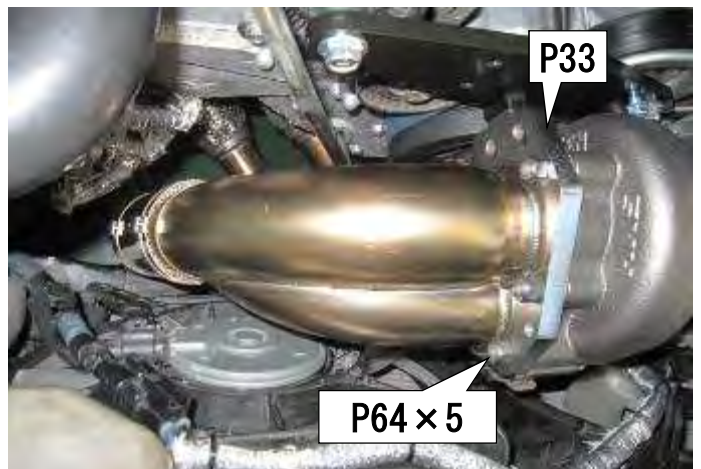

(5) Install the Turbocharger Bracket No.3 using the provided Hexagon Nut M8 L15 and Flat Washer M8 as shown in the photo on the right. Temporarily install the Flange Bolt M6 L10.

- P12: Turbocharger Bracket No.3 x 1
- P57: Hexagon Bolt M8 L15 x 4
- P58: Flat Washer M8 x 4
- P71: Flange Bolt M6 L10 x 1

NOTE

Do not use the flange bolt here since the bracket seat surface is narrow.
Flange Bolt M6 L10 is to install the insulator.

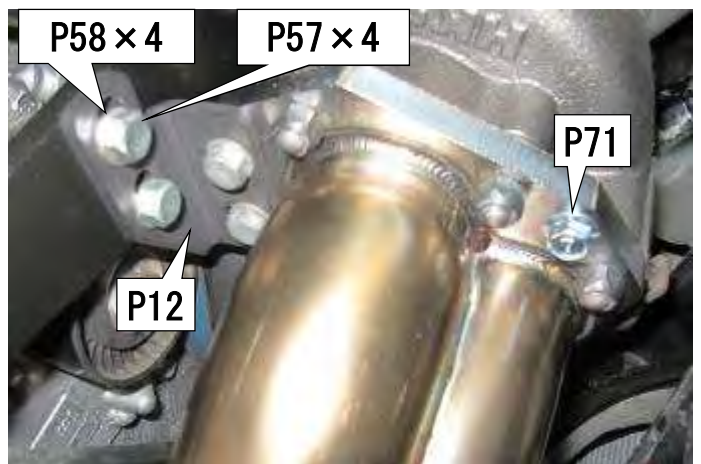

(6) Install the front pipe side's extension using the provided Gasket, Hexagon Bolt M10 L40, Flat Washer M10, and Hexagon Nut M10. Tighten the Extension Bracket installed in 5 (4) together.

- P34: Gasket x 1
- P59: Hexagon Bolt M10 L40 x 2
- P60: Flat Washer M10 x 4
- P61: Hexagon Nut M10 x 2

(7) Install the A/F sensor and O₂ sensor to the extension. Completely tighten the nut temporarily installed to the Exhaust Manifold.

NOTE

To easily determine the installation positions, temporarily install the bolts; then gradually tighten them.

9. INSTALLATION OF TURBOCHARGER ACCESSORY PARTS

PARTS LIST

No.	Description	Qt
P15	Banjo Bolt M12 P1.25	1
P16	Copper Washer 12×17	2
P26	Water Line Banjo No.1	1
P27	Water Line Banjo No.2	1
P28	Banjo Bolt M14	2
P29	Copper Washer 14×20	4
P30	Hose φ8 L=1250mm	1
P53	Insulator	1
P75	Hose Clamp Mark 130	2
P80	Tie Wrap M	3

- (1) Disconnect the water line hose that is connected from the side of the throttle to the engine rear side from the engine rear side. Cut the hose as shown in the photo on the right. Route the hose under the intake manifold to the turbine side.

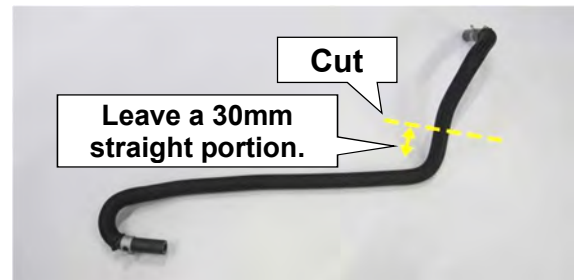

- (2) Install the Water Line Banjo No.1 to the turbocharger using the provided Banjo Bolt M14 and Copper Washer 14×20.

- P26: Water Line Banjo No.1 x 1
 - P28: Banjo Bolt M14 x 1
 - P29: Copper Washer 14x20 x 2
- Tightening Torque : N · m (kgf·m)
M14 : T= 33~41 (3.4~4.2)

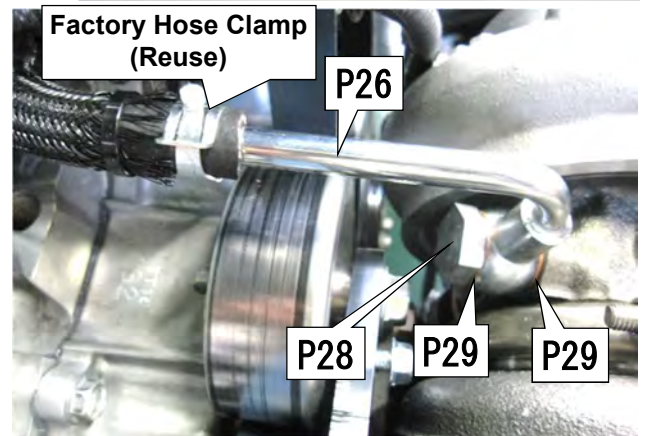

- (3) Connect the hose removed in (1) and the Water Line Banjo No.1 as shown in the photo on the right. Reuse the factory hose clamp.

- (4) Install the Water Line Banjo No.2 to the turbocharger using the provided Banjo Bolt M14 and Copper Washer 14×20.

- P27: Water Line Banjo No.2 x 1
 - P28: Banjo Bolt M14 x 1
 - P29: Copper Washer 14×20 x 2
- Tightening Torque : N · m (kgf·m)
M14 : T= 33~41 (3.4~4.2)

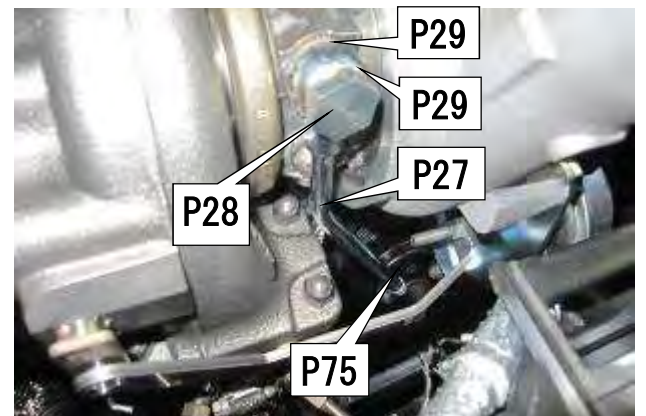

(5) Cut the provided Hose $\phi 8$ to 1200mm in length. Connect the Water Line Banjo No.2 with the water line hose removed in (1). Secure the hose with the provided Hose Clamp Mark 130 as shown in the photo on the right.

- P30: Hose $\phi 8$ L=1250mm x 1
- P75: Hose Clamp Mark 130 x 2

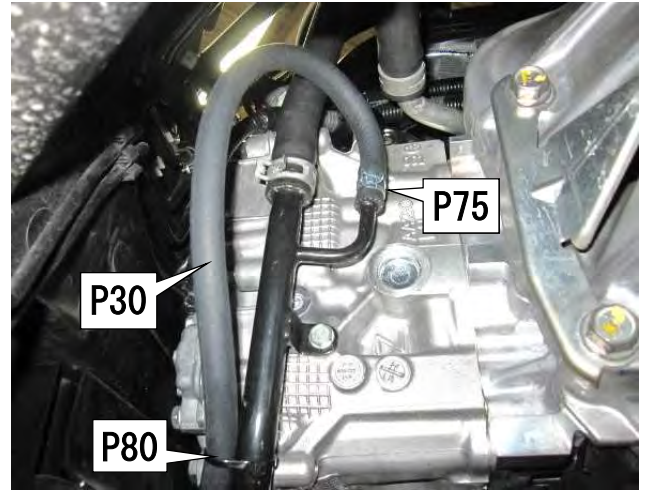

(6) Secure the hose with the provided Tie Wrap M.

- P80: Tie Wrap M x 3

NOTE

Make sure the hose $\phi 8$ does not come in contact with any rotating part such as a belt, the engine and/or shroud.



(7) Install the Oil Inlet Banjo temporarily installed in the section 3 to the turbocharger using the provided Banjo Bolt M12 and Copper Washer 12x17.

- P15: Banjo Bolt M12 x 1
- P16: Copper Washer 12x17 x 2

● Tightening Torque : N · m (kgf · m)
M12 : T= 17~23 (1.8~2.4)

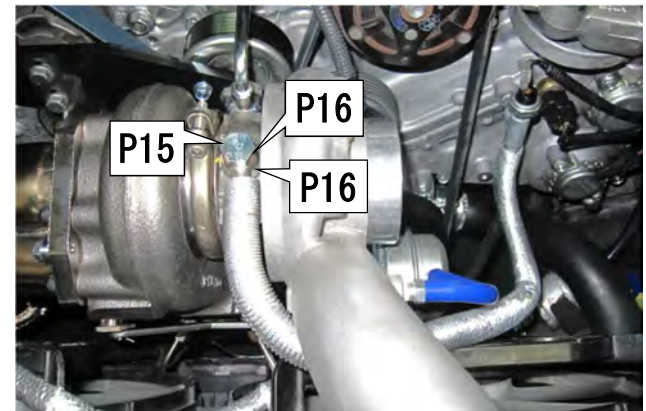

(8) Tighten the Oil Inlet Banjo completely.

NOTE

Route the oil inlet hose as shown in the photo on the right.

(9) Insert the Insulator into the Flange Bolt M6 L10 temporarily installed in 4.(5) and 8.(5) and tighten the bolts.

- P53: Insulator x 1

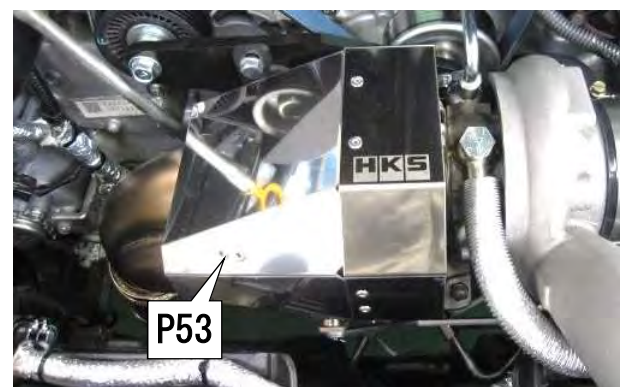

10. INSTALLATION OF AIR CLEANER and SUCTION PIPE

PARTS LIST

		No.	Description	Qt	
		P4	Suction Pipe	1	
		P41	Air Cleaner	1	
		P42	Air Cleaner Bracket No.1	1	
		P43	Air Cleaner Bracket No.2	1	
		P44	Silicone Hose φ80	2	
		P47	Hose Band #52	4	
		P51	Hose φ12 L=200mm	1	
		P52	Joint Pipe φ12	1	
		P69	Flange Nut M6	1	
		P70	Flange Bolt M6 L15	1	
		P73	Hose Clamp Mark 180	2	

- (1) Temporarily install the Air Cleaner Bracket No.1 and No.2 using the provided Flange Bolt M6 L15 and Flange Nut M6. Temporarily install these brackets to the vehicle body using a factory bolt. Place the Air Cleaner on the brackets and determine the bracket installation position; then, tighten the bolt and nut completely.

- P42: Air Cleaner Bracket No.1 x 1
- P43: Air Cleaner Bracket No.2 x 1
- P68: Flange Nut M6 x 1
- P69: Flange Bolt M6 L15 x 1

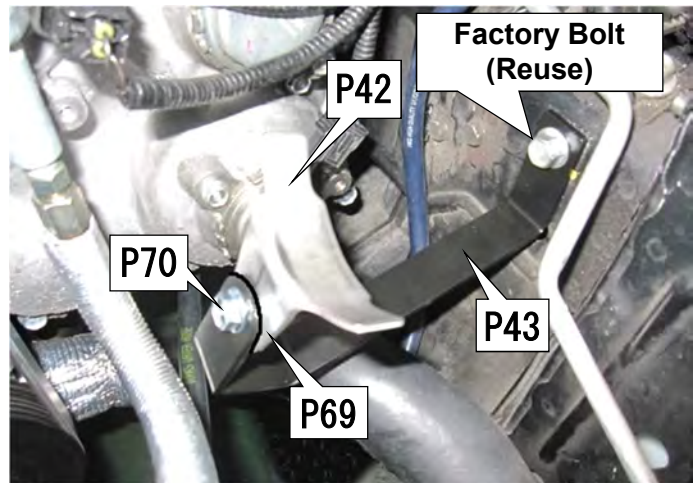

- (2) Connect the Air Cleaner to the Suction Pipe using the provided Silicone Hose φ80. Secure the hose with the provide Hose Band #52.

- P4: Suction Pipe x 1
- P41: Air Cleaner x 1
- P44: Silicone Hose φ80 x 2
- P47: Hose Band #52 x 4

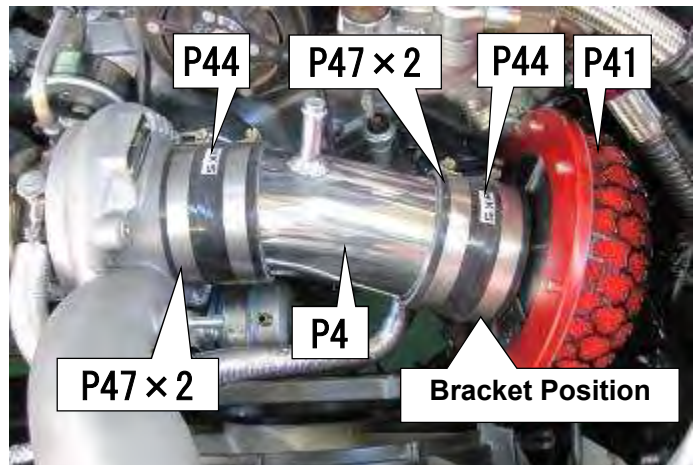

(3) Cut the Hose ϕ 12 to 150mm in length.

- P51: Hose ϕ 12 L=200mm x 1

(4) Relocate the factory blow-by hose to the left side of the A/C compressor. Connect the Hose ϕ 12 cut in (3) to the Joint Pipe. Secure the pipe with the provided Hose Clamp Mark 180 and stock hose clamp as shown in the photo on the right.

- P52: Joint Pipe ϕ 12 x 1
- P73: Hose Clamp Mark 180 x 1



(5) Connect the Hose ϕ 12 from the Joint Pipe to the Suction Pipe. Secure the hose using the provided Hose Clamp Mark 180.







- P73: Hose Clamp Mark 180 x 1

NOTE

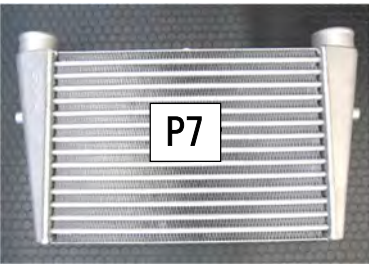
Make sure the air cleaner does not come in contact with any other parts of the vehicle. Adjust the position of the air cleaner bracket if the air cleaner comes in contact with any other parts of the vehicle.

11. INSTALLATION OF INTERCOOLER

PARTS LIST

		No.	Description	Qt
		P7	Intercooler	1
		P35	Intercooler Bracket No.1	1
		P36	Intercooler Bracket No.2	1
		P37	Intercooler Bracket No.3	1
		P38	Intercooler Bracket No.4	1
		P39	Spacer ϕ 16	2
		P65	Flange Bolt M8 L10	1
		P66	Flange Bolt M8 L15	5
		P67	Flange Nut M8	2
		P68	Flange Bolt M6 L35	2
		P69	Flange Nut M6	2

(1) Install the stock reinforcement modified in the section 2 and front bumper bracket.

(2) Insert the provided Spacer ϕ 16 between the front bumper bracket and Intercooler Bracket No.3. Install the brackets using the Flange Bolt M6 L35 and Flange Nut M6.

- P37: Intercooler Bracket No.3 x 1
- P39: Spacer ϕ 16 x 2
- P68: Flange Bolt M6 L35 x 2
- P69: Flange Nut M6 x 2

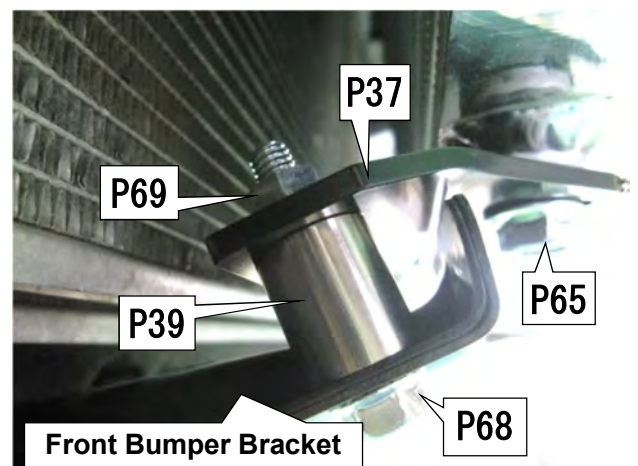

(3) Temporarily install the Intercooler Bracket No.1 and No.2 using the Flange Bolt M8 L15 and Flange Nut M8.

- P35: Intercooler Bracket No.1 x 1
- P36: Intercooler Bracket No.2 x 1
- P66: Flange Bolt M8 L15 x 2
- P67: Flange Nut M8 x 2

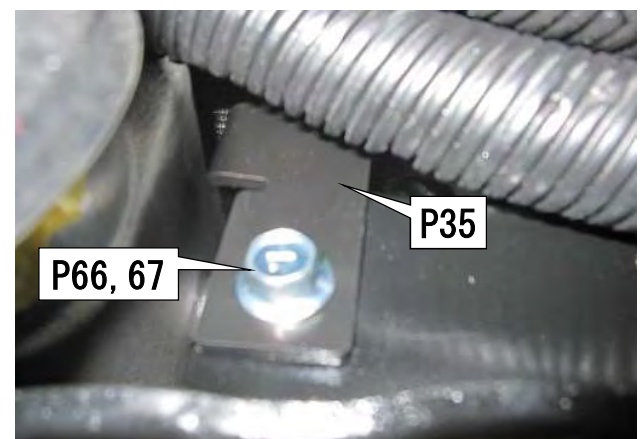

(4) Temporarily install the Intercooler.
To install the intercooler, use the Flange Bolt M8 L15 for the side of the Intercooler, and use the Flange Bolt M8 L10 for the lower side.

- P65: Flange Bolt M8 L10 x 1
- P66: Flange Bolt M8 L15 x 2

NOTE

Make sure to use the Flange Bolt M8 L10 to install the lower side of the Intercooler.

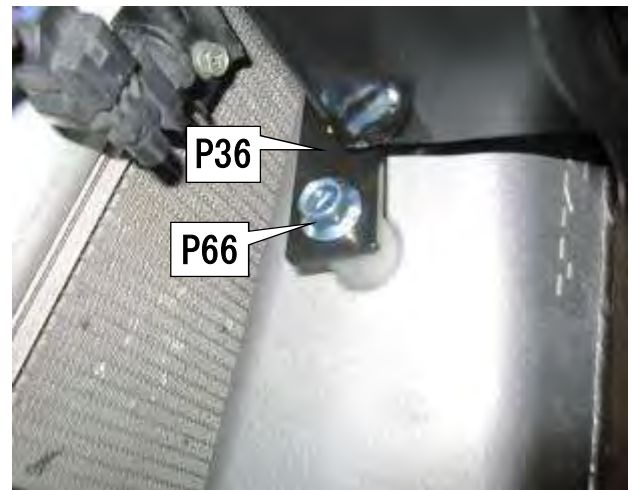
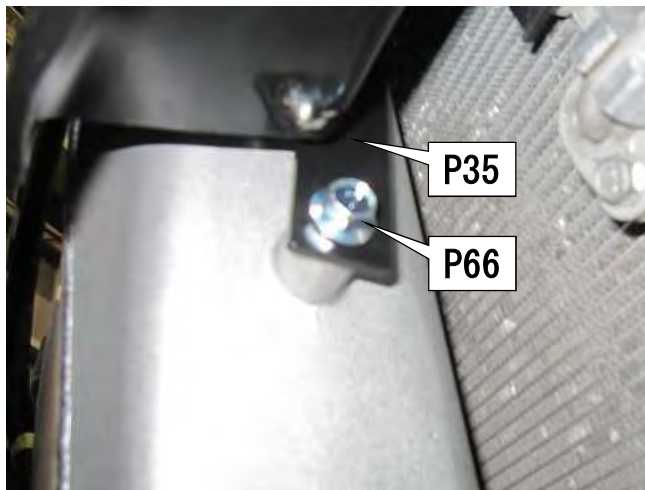
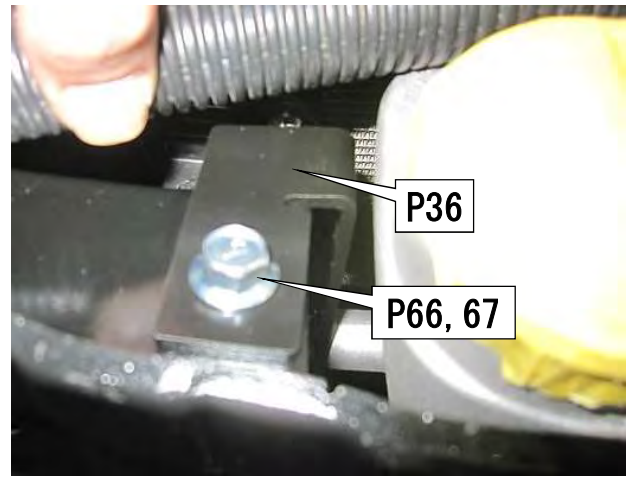

(5) Tighten all bolts completely after making sure the Intercooler does not come in contact with any other parts of the vehicle.

NOTE

Make sure to install the intercooler horizontally by adjusting the bolt position within the oval-shaped bolt hole.

(6) Install the Intercooler Bracket No.4 using the Flange Bolt M8 L15.

- P38: Intercooler Bracket No.4 x 1
- P66: Flange Bolt M8 L15 x 1





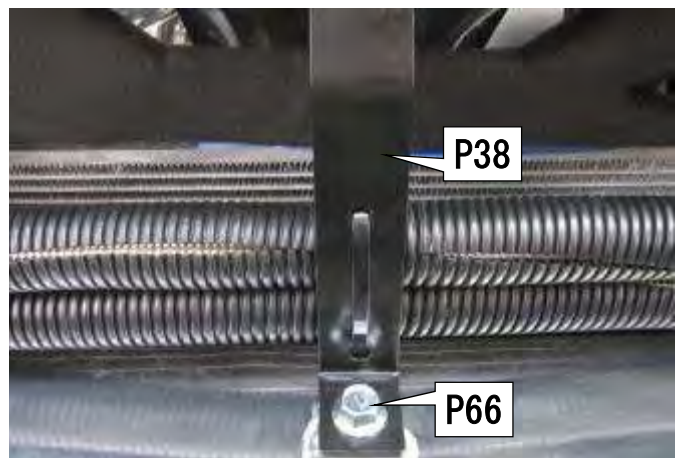

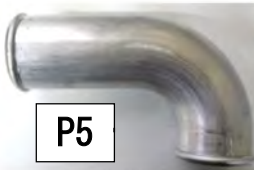

NOTE

The hole in the center of the Intercooler Bracket No.4 is to install the oil cooler kit that is available separately.



12. INSTALLATION OF PIPING

PARTS LIST

		No.	Description	Qt
		P5	Intercooler Pipe	2
		P6	Chamber Pipe	1
		P45	Silicone Hose φ60	4
		P46	Silicone Hose φ70	1
		P48	Hose Band #48	2
		P49	Hose Band #40	8
		P78	Button Bolt M4 L10	2
		P83	Insulator Sheet 300mm×300mm	1
				
				

- (1) Install the Intercooler Pipe using the provided Silicone Hose φ60 and Hose Band #40.

- P5: Intercooler Pipe x 1
- P45: Silicone Hose φ60 x 2
- P49: Hose Band #40 x 2

NOTE

Cut off the portion of the factory radiator sponge where comes in contact with the pipe.

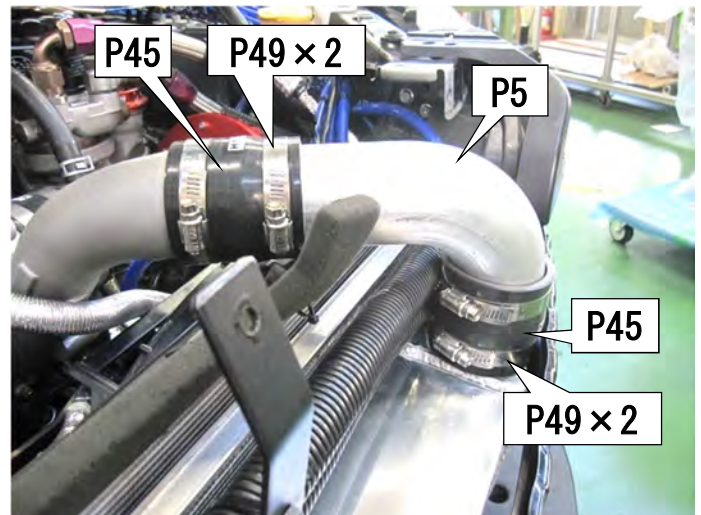

- (2) Install the Intercooler Pipe and Chamber Pipe using the provided Silicone Hose φ60 and Hose Band #40. Use the Silicone Hose φ70 for the throttle side and Hose Band #48.

- P5: Intercooler Pipe x 1
- P6: Chamber Pipe x 1
- P45: Silicone Hose φ60 x 2
- P46: Silicone Hose φ70 x 1
- P48: Hose Band #48 x 2
- P49: Hose Band #40 x 4

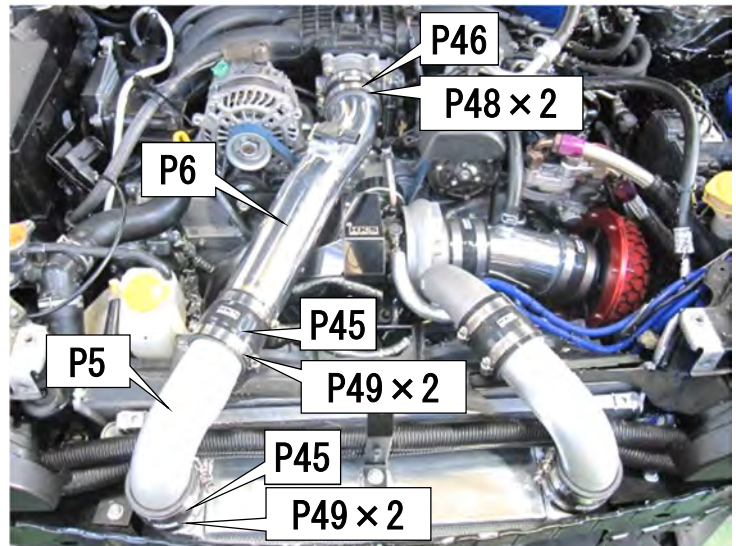

- (3) Cut the Insulator Sheet to an appropriate size. Wrap the air-flow sensor wire with the Insulator Sheet and secure the wire with a wire as shown in the photo on the right.

- P83: Insulator Sheet 300mm×300mm x 1

- (4) Install the air-flow sensor to the Chamber Pipe using the provided Button Bolt M4 L10.

- P78: Button Bolt M4 L10 x 2

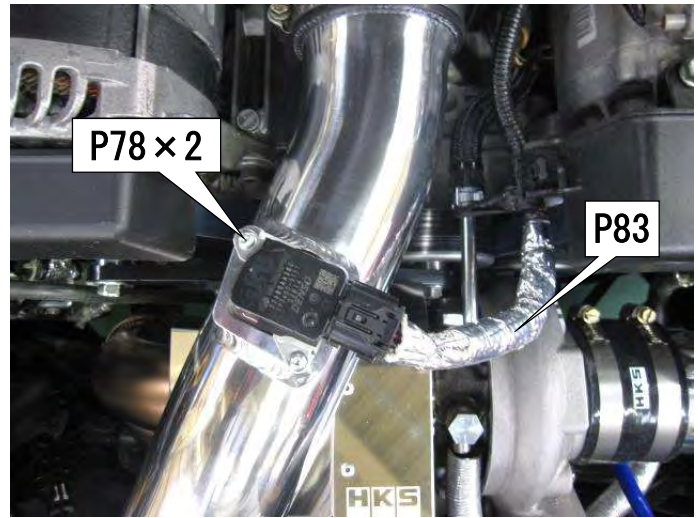

13. REINSTALLATION OF FACTORY PARTS

Use this instruction manual and the manufacturer's service manual as a reference.

PARTS LIST

 P81	No.	Description	Qt
	P69	Flange Nut M6	1
	P70	Flange Bolt M6 L15	1
	P81	Sponge Sheet 50mm×50mm	2

(1) Affix the Sponge Sheet to the back of the radiator support around the pipe.

- P81: Sponge Sheet 50mm×50mm x 2

(2) Reinstall the radiator support.

NOTE

Adjust each pipe's position so the radiator support does not come in contact with the pipe.



(3) Install the Intercooler Bracket No.4 installed in 11.(6) to the radiator support using the provided Flange Bolt M6 L15.

- P70: Flange Bolt M6 L15 x 1

NOTE

Make sure the intercooler and pipes do not come in contact with any other parts of the vehicle.

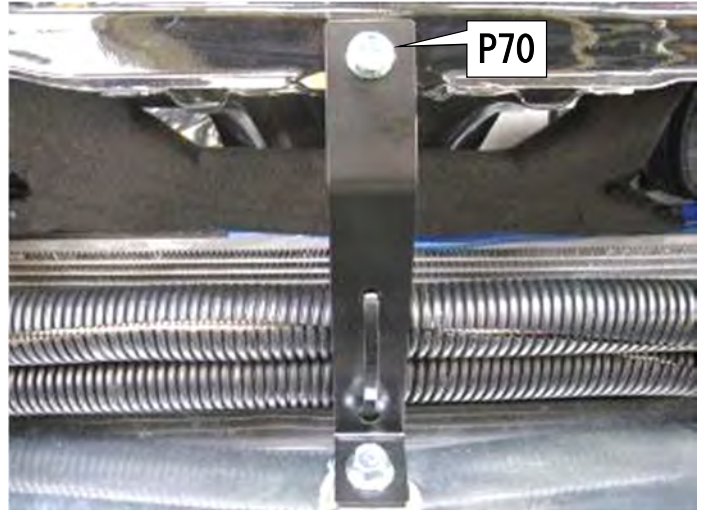

(4) Install the horn to the bolt installed to the reinforcement in 2.(2) using the provided Flange Nut M6.

- P69: Flange Nut M6 x 1

NOTE

The photo on the right shows the vehicle with the oil cooler kit that is available separately.

Make sure each part does not come in contact with any other parts of the vehicle.



(5) Relocate the sponge on the hood support rod to the position shown in the photo on the right.

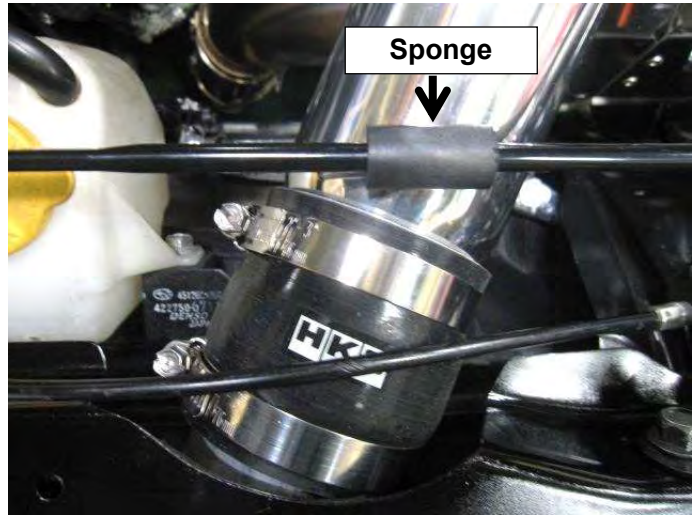

(6) Reinstall ⑧front bumper bracket and ⑦front bumper cover.

(7) Reinstall ③front bumper energy absorber.

(8) Reinstall ②front bumper.

(9) Reinstall ①side-mounted turn signal to both side.

(10) Reinstall the engine under cover.

(11) Reconnect the negative cable to the battery.

(12) Refill the engine oil and coolant.



14. CONFIRMATION AFTER INSTALLATION

- Use the insulator sheet included in this kit to affix to high temperature areas around the turbocharger, exhaust parts, etc.
 - P82, P83: Insulator Sheet
- Use the tie wraps and sponge sheet included in this kit to prevent unnecessary contact between the parts.
 - P79, P80: Tie Wrap ▪ P81: Sponge Sheet
- After the installation process is complete, check all items listed in the “Confirmation after Installation” section of the Instruction Manual.

15. TECHNICAL INFORMATION

● Initial Boost Pressure Adjustment

The boost pressure actuator is set to 89kPa(0.9kgf/cm²).

Actual boost pressure may be different due to the size of exhaust, front pipe and etc. Engine power output and torque may be different due to the vehicle situation.



Caution

- Without upgrading the engine parts, please use stock front pipe with catalytic converter. When using front pipe without catalytic converter can increase boost pressure and the power output could be over the allowance range of a stock engine. May cause damage to the engine.

- To increase boost pressure more than initial setting, a boost controller such as HKS EVC is required. Please set up according to the specifications of vehicle engine and drive train parts.

※ Extreme boost may cause damage to the engine and drive train.

※ **When increasing boost pressure, please do not adjust with actuator.**

- To decrease initial boost pressure use actuator. Adjusting the length of actuator can accelerate the opening timing of swing valve. Boost pressure tends to gradually increase with engine RPM.

【work procedure】

- ① Loosen the nut on the actuator rod and adjust the plate position.
- ② Loosen the nut to the end side of actuator and also slide the plate position to the end side. Finally fixed by the lock nut.
 - ※ Loosening the plate position by 2mm reduces the boost pressure approximately by 9.8kPa(0.1kgf/cm²).
 - ※ Loosen the nut up to 3mm.Improper adjustment may cause damage to the actuator internal parts.
- ③ When the initial boost pressure is reduced with actuator rod, the boost interception point shifts and becomes milder. Boost pressure tends to gradually increase with engine RPM. Please check the actual boost pressure characteristics after adjustment with a boost meter.

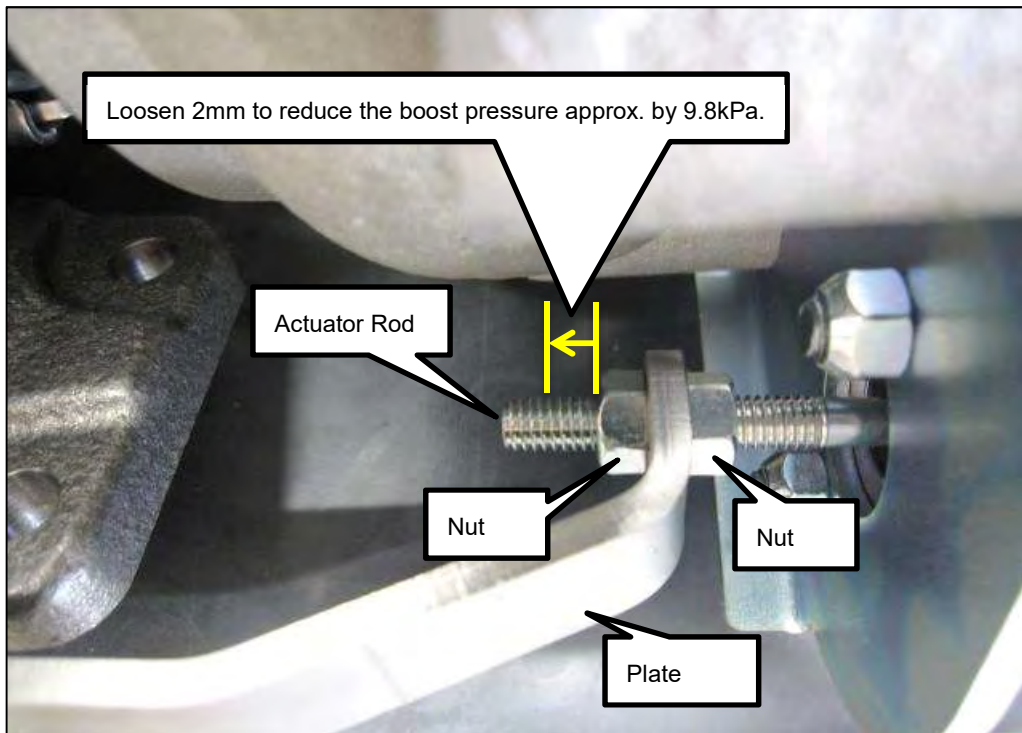

Caution

- The temperature near engine and turbo charger is very high after running. Please adjust after completely cool-down. May cause a burn.

● Boost up graph of decreasing initial boost pressure of actuator

Loosening the nut up to maximum 3mm to decrease the initial boost pressure

※ Stock engine

① Stock front pipe (within catalytic converter)

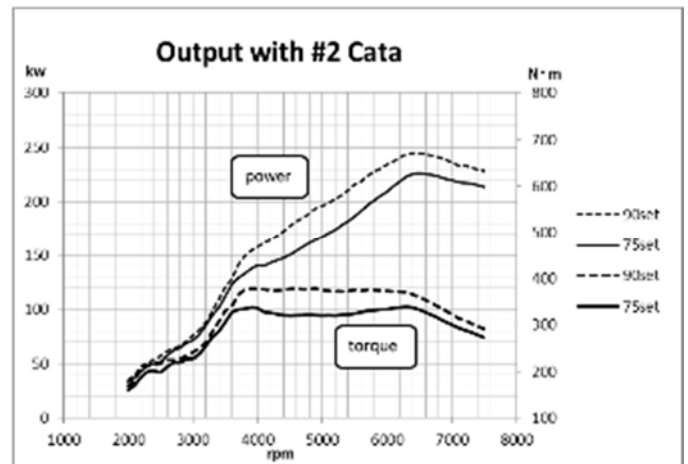
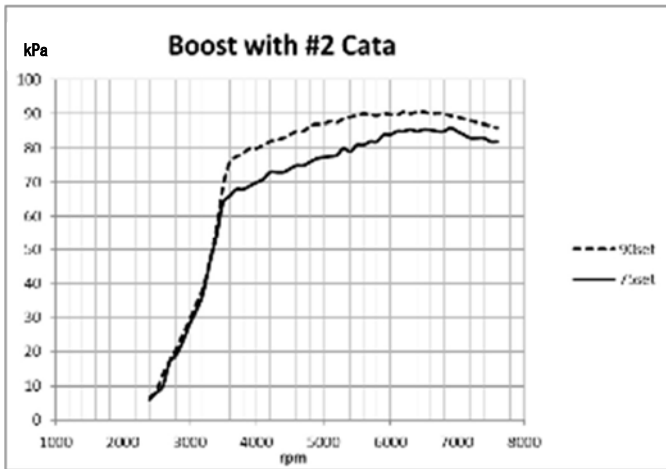

② Front pipe without catalytic converter.

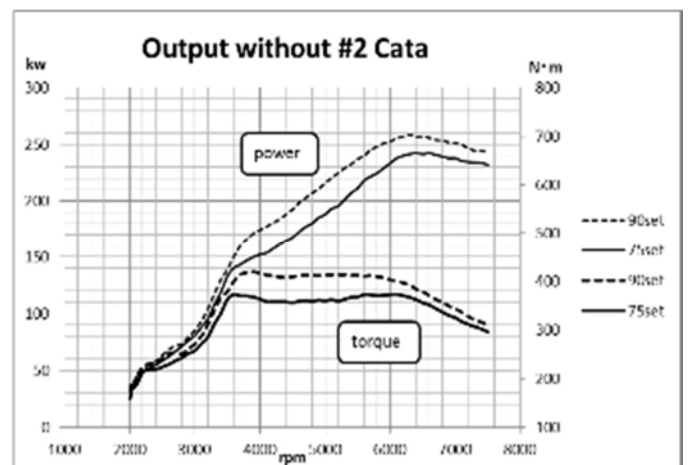
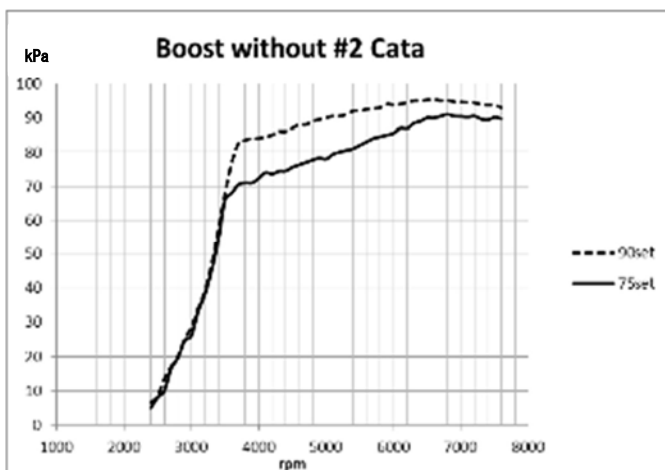

90set . . . Factory boost pressure setting

75set . . . Loosening the nut by 3mm reduces the boost pressure approximately by 75kPa

● The actual values may be different from the test graph due to the exhaust, front pipe and setting of fuel control and/or other vehicle specifications.

This information is provided for reference only. Please test on actual vehicle.



HKS Co., Ltd.

7181 Kitayama, Fujinomiya, Shizuoka 418-0192, Japan

<https://www.hks-power.co.jp/en/>