

BOLT-ON TURBO PRO KIT GT4525

INSTALLATION MANUAL



Installation must be done by a professional.

Read this manual prior to the installation.

Always have access to this manual as well as a factory service manual.

PRODUCT NAME	BOLT-ON TURBO PRO KIT GT4525
PURPOSE	AUTOMOBILE PARTS
PART NUMBER	11001-AT007 : With ϕ 100 catalyzer 11001-KT003 : No catalyzer 11001-KT005 : With ϕ 113 catalyzer
MANUAL NUMBER	E04211-T59050-00 Ver.3-3.02
VEHICLE	• TOYOTA 86 (DBA-ZN6、4BA-ZN6) Grade: GT/GT Limited and models with 17-inch wheels • SUBARU BRZ (DBA-ZC6、4BA-ZC6) Grade: R/RA/S/ts/tsGT/GT/STI and models with 17-inch wheels
ENGINE	FA20
MODEL YEAR	• TOYOTA 86: 2012/4~ • SUBARU BRZ: 2012/3~
REMARKS	[NOTE] <ul style="list-style-type: none">• HKS is not responsible with the damage to the engine and/or other parts of a vehicle after installing this product.• An injector, fuel pump, engine management device, engine plug are not included in this product.• Modification of the radiator support, reinforcement, fan shroud, oil pan, etc. is required.• Check the spark plugs occasionally and replace them if necessary.• Resetting by an engine management device must be done. Resetting of fuel and ignition must be done to avoid engine damage..• Change the engine oil to the one with 40 or higher viscosity at high temperatures.• The boost pressure of the provided actuator is set to approximately 55-65 kPa.• Please keep the attached exhaust emission test result certification. (11001-AT007 only).• The oil return pipe needs to be welded. If welding is not possible, please use with our optional oil pan (11999-AT001)• Stainless steel wire is used for mounting the heat shield.• Use ThreeBond TB1324 or similar anaerobic sealant.

※This application was confirmed by December, 2022

Rev. Number	Date	Manual Number	Details
3-3.01	2021/7	E04211-T59030-00	1 st Edition
3-3.02	2022/12	E04211-T59050-00	2 nd Edition

Published in December, 2022 by HKS Co., Ltd. (Unauthorized reproduction is strictly prohibited.)

INDEX

NOTICE/ATTENTION	1
PARTS LIST	2
1. REMOVAL OF FACTORY PARTS	5
2. MODIFICATION OF FACTORY PARTS	8
3. INSTALLATION OF OIL INLET PARTS	14
4. INSTALLATION OF TURBOCHARGER BRACKET	16
5. INSTALLATION OF EXHAUST MANIFOLD	18
6. ASSEMBLY OF TURBOCHARGER	21
7. INSTALLATION OF TURBOCHARGER AND OIL RETURN HOSE	22
8. INSTALLATION OF EXTENSION PIPE (For 11001-AT007)	24
8. INSTALLATION OF EXTENSION PIPE (For 11001-KT003)	26
8. INSTALLATION OF EXTENSION PIPE (For 11001-KT005)	28
9. INSTALLATION OF THE CAM POSITION SENSOR INSULATOR	31
10. INSTALLATION OF TURBUCHARGER INSULATOR PARTS	32
11. INSTALLATION OF AIR CLEANER AND SUCTION PIPE	36
12. INSTALLATION OF INTERCOOLER	38
13. INSTALLATION OF PIPING	40
14. REINSTALLATION OF FACTORY PARTS	42
15. CONFIRMATION AFTER INSTALLATION	44

NOTICE

Thank you for purchasing HKS BOLT-ON TURBO PRO KIT. This manual assumes that you have and know how to use the tools and equipment necessary to safely perform service operations on your vehicle. This manual assumes that you are familiar with typical automotive systems and basic service and repair procedures. Do not attempt to carry out the operations shown in this manual unless these assumptions are correct. Always have access to a factory repair manual. To avoid injury, follow the safety precautions contained in the factory repair manual.

ATTENTION

- This manual indicates items you need to pay attention to in order to install this product safely and lists precautions to avoid any possible damage and/or accidents.
- This product is an automobile part. Do not use for any other purposes.
- HKS will not be responsible for any damage caused by incorrect installation and/or use, or use after modification and/or dismantling of this product.
- This product was designed based on installation onto a specific factory vehicle.
- The specifications of this product are subject to change without notice.
- The instructions are subject to change without notice. Make sure to refer to the most recent instructions.

SAFETY PRECAUTIONS

The following precautions for use of this product are to prevent possible accidents and/or injuries and for proper use.



WARNING

Indicates risk of serious injury and/or possible death.



CAUTION

Indicates risk of damage to people or large-scale damage to property.
(Large-scale damage is the damage caused by a product defect.
Ex. Damage to a vehicle, burnout, etc.)

PARTS LIST**No.1**

No.	Description	QT	Remarks
1	Turbocharger Assembly	1	GT4525
2	Exhaust Manifold	1	
3	Suction Pipe $\phi 80$	1	
4	Intercooler Pipe $\phi 60$	2	
5	Chamber Pipe $\phi 70$	1	
6	Turbocharger Bracket No.1	1	t = 9mm
7	Stepped Spacer O.D. $\phi 20$	1	
8	Spacer O.D. $\phi 20$	1	
9	Turbocharger Bracket No.2	1	Lower side of T/C
10	Turbocharger Bracket No.3	1	Side of T/C
11	Oil Inlet Hose L=460mm	1	
12	Oil Inlet Banjo	1	
13	T-fitting PT1/8	1	
14	Hexagon Fitting	1	
15	Oil Line Fitting	1	
16	Thermal Tube $\phi 21$	1	
17	Oil Outlet Pipe	1	
18	Gasket	1	For oil outlet pipe
19	Oil Return Pipe	1	For oil pan welding
20	Hose $\phi 16$ L=250mm	1	
21	Thermal Tube $\phi 30$ L=500mm	1	
22	Hose $\phi 8$ L=1250mm	1	
23	Gasket	2	Exhaust manifold E/G side
24	Intercooler	1	
25	Intercooler Bracket No.1	1	Left
26	Intercooler Bracket No.2	1	Right
27	Intercooler Bracket No.3	1	Lower
28	Intercooler Bracket No.4	1	Upper
29	Spacer O.D. $\phi 16$	2	
30	Extension Bracket	1	
31	Air Cleaner	1	$\phi 200-80$
32	Air Cleaner Bracket No.1	1	
33	Air Cleaner Bracket No.2	1	
34	Silicone Hose $\phi 80$	2	
35	Silicone Hose $\phi 60$	4	
36	Silicone Hose $\phi 70$	1	
37	Hose Band #52	4	#52
38	Hose Band #48	2	#48

PARTS LIST**No.2**

No.	Description	QT	Remarks
39	Hose Band #40	8	#40
40	Hose Band #28	2	#28
41	Hose φ12 L=200mm	1	
42	Joint Pipe φ12	1	
43	Insulator φ50 L=100mm	1	For exhaust manifold
44	Insulator	1	For camshaft position sensor
45	Spacer (φ20-M8 L=15mm)	2	
46	Cap Bolt M6 L=30	2	
47	Flat Washer M6 Large Diameter	2	
48	Flange Bolt M10 L50 7-mark	2	
49	Hexagon Bolt M8 L15	8	
50	Flat Washer M8	8	
51	Oil Level Gauge Pipe Bracket No.1	1	Main body of the bracket
52	Oil Level Gauge Pipe Bracket No.2	1	Pipe holder
53	Flange Bolt M6 L10	2	Pipe fixing
54	Flat Washer M6	2	
55	Flange Nut M6	2	
56	Hexagon Bolt M10 L40	2	
57	Flat Washer M10	4	
58	Hexagon Nut M10	2	
59	Stud Bolt M8 13-9-16	9	
60	Lock Nut M8	4	
61	Flange Bolt M8 L10	1	
62	Flange Bolt M8 L15	5	
63	Flange Nut M8	2	
64	Flange Bolt M6 L35	2	
65	Flange Nut M6	5	
66	Flange Bolt M6 L15	5	
67	Hose Clamp Mark 230	2	
68	Hose Clamp Mark 130	3	
69	Hose Clamp Mark 180	3	
70	Hose Clamp Mark 138	1	
71	Hose Clamp Mark 115	3	
72	Rubber Cap φ16	1	
73	Button Bolt M4 L10	2	
74	Tie Wrap L	10	
75	Tie Wrap M	10	
76	Sponge Sheet 50mm×50mm	5	

PARTS LIST**No.3**

No.	Description	QT	Remarks
77	Insulator Sheet 70mm×1000mm	1	
78	Insulator Sheet 300mm×300mm	2	
79	Water Line Banjo No.1	1	
80	Water Line Banjo No.2	1	
81	Banjo Bolt M12 P1.5	3	Water and oil
82	Copper Washer φ12×φ17	6	
83	Gasket	1	Exhaust manifold T/C side
84	Gasket	1	Extension T/C side
85	Installation Manual	1	The Book
86	Instruction Manual	1	
87	Flange Bolt M6 L10	2	
88	Lock Nut M8	5	
	11001-AT007 (φ100 catalyzer)		
89	Extension Pipe	1	The catalyzer with exhaust gas conformity plate
90	Gasket	1	Extension Exhaust side
91	Insulator φ100 No.1	1	For T/C upper
92	Insulator φ100 No.2	1	For T/C lower
93	Flange Bolt M6 L10	4	
94	Exhaust emission test result certification	1	
	11001-KT003 (No catalyzer)		
95	Extension Pipe	1	No Catalyzer
96	Gasket	1	Extension Exhaust side
97	Insulator No.1	1	For turbocharger
98	Insulator φ60 L=120mm	1	For extension
99	Hose Band #40	2	#40
	11001-KT005 (φ113 catalyzer)		
100	Extension Pipe	1	With catalyzer
101	Gasket	1	Extension Exhaust side
102	Insulator No.1	1	For turbocharger
103	Insulator φ113 No.1	1	For catalyzer
104	Insulator φ113 No.2	1	For catalyzer
105	Insulator φ60 L=120mm	1	For extension
106	Hose Band #64	2	#64
107	Hose Band #40	2	#40

1. REMOVAL OF FACTORY PARTS

Use this instruction manual and the manufacturer's service manual as a reference.

PARTS LIST

The parts list number shown in the table on the right corresponds to the number of the parts list on page 2-4.

No.	Description	QT
P72	Rubber Cap ϕ 16	1

- (1) Disconnect the negative cable from the battery.
- (2) Remove the engine under cover. (The removed cover will be reinstalled later.)
- (3) Remove ① side-mounted turn signal from both sides. (The removed signals will be reinstalled later.)
- (4) Remove ② front bumper. (The removed bumper will be reinstalled later.)
- (5) Drain the engine oil and coolant.

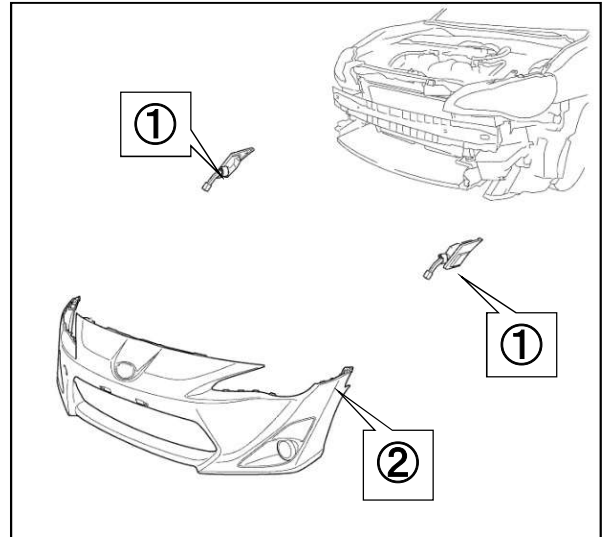

- (6) Remove ③ front bumper energy absorber. (The removed absorber will be modified and reinstalled later.)
- (7) Remove ④ front bumper reinforcement plate from both sides
- (8) Remove ⑤ radiator cover plate.
- (9) Remove ⑥ horn. (The removed horn will be reinstalled later.)
- (10) Remove ⑦ front bumper cover LWR. (The removed cover will be reinstalled later.)
- (11) Remove ⑧ front bumper bracket; then remove the front bumper support. (The removed bracket will be reinstalled later. The removed support will be modified and reinstalled later.)

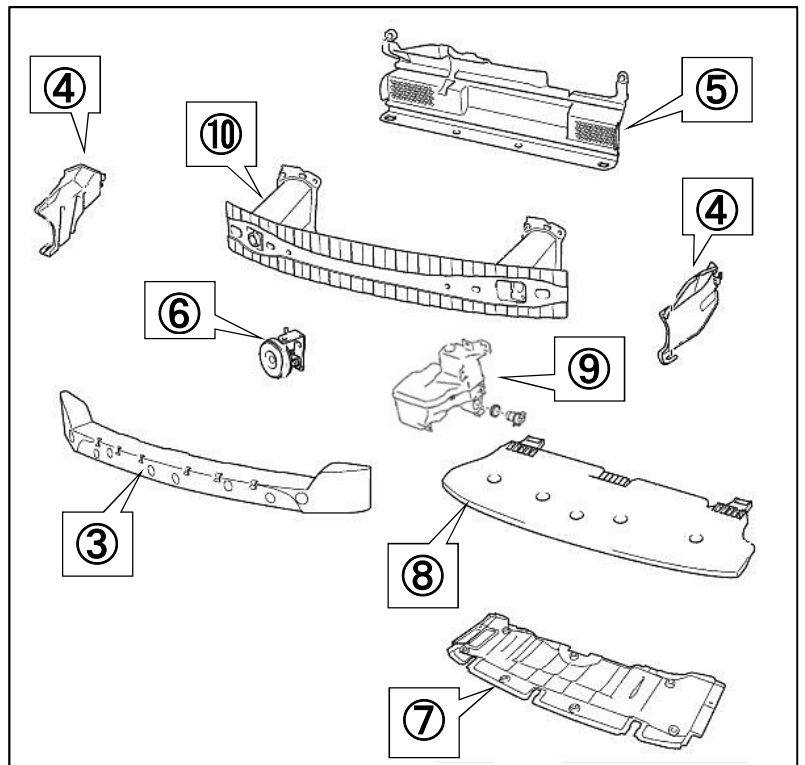

- (12) Shift ⑨ washer tank and remove ⑩ reinforcement. (The removed reinforcement will be modified and reinstalled later.)

(13) Remove ⑪air cleaner case.

(14) Remove ⑫air cleaner duct.

(15) Remove ⑬hood lock from the radiator support. (The removed lock will be reinstalled later.)

(16) Remove ⑭radiator support. (The removed support will be reinstalled later.)

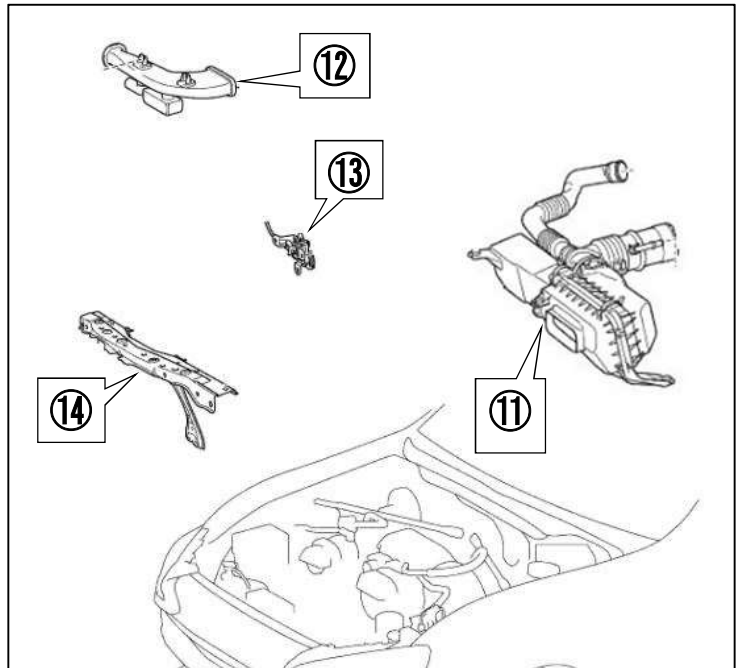

(17) Remove ⑮air cleaner duct, ⑯chamber, and ⑰hose.

(18) Install the Rubber Cap ϕ 16 to the hole ⑰hose was removed from.

• P72: Rubber Cap ϕ 16 \times 1

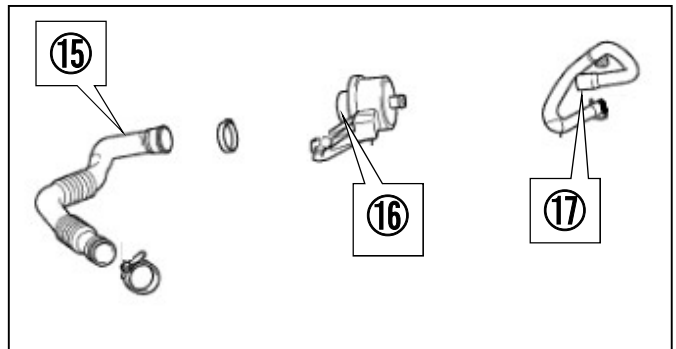

(19) Remove ⑱air cleaner case bracket. The removed bolt will be reused later.

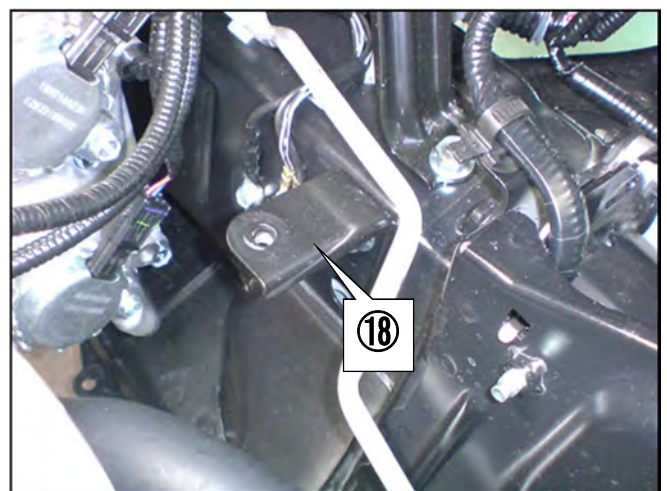

(20) Remove ⑱ fan shroud. (The removed shroud will be modified and reinstalled later.)

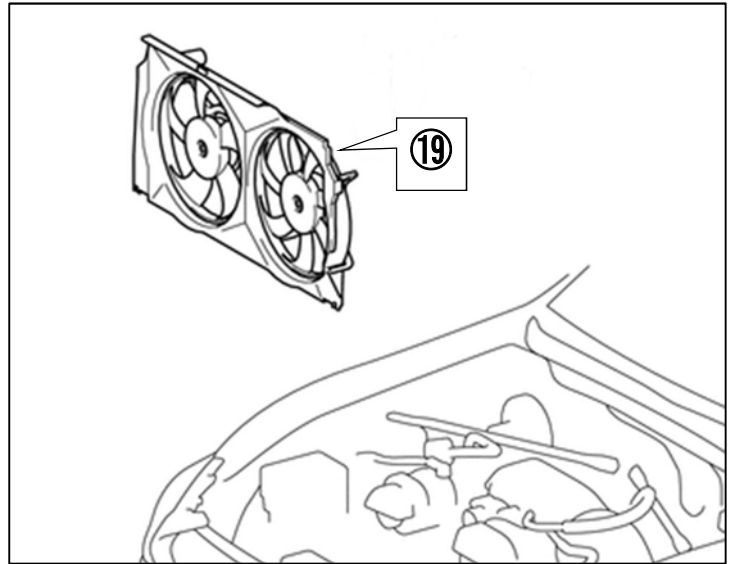

(21) Remove ⑳ exhaust manifold. (The removed nut will be reused later.)

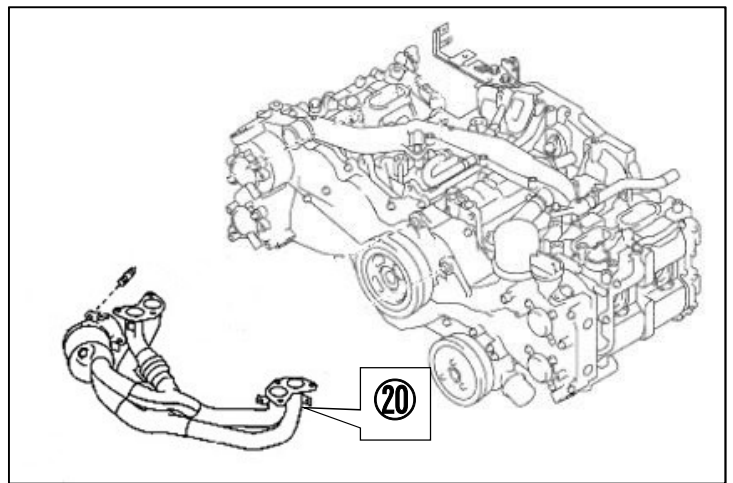

(22) Remove ㉑ oil pan. (The removed pan will be modified and reinstalled later.) The removed bolt and seals will be reused later.

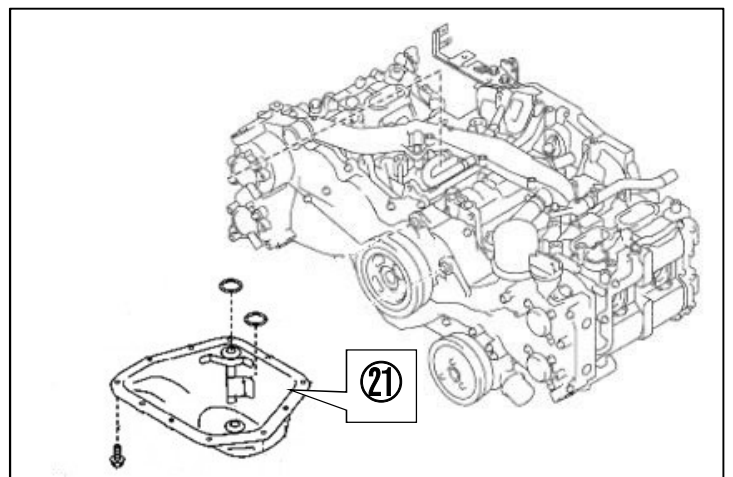

2. MODIFICATION OF FACTORY PARTS

PARTS LIST

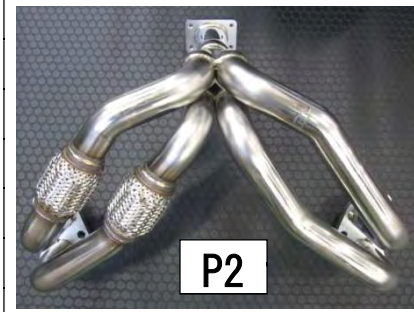

No.	Description	QT
P2	Exhaust Manifold	1
P19	Oil Return Pipe	1
P23	Gasket	2
P65	Flange Nut M6	1
P66	Flange Bolt M6 L15	1
P68	Hose Clamp Mark 130	1
P69	Hose Clamp Mark 180	1
P70	Hose Clamp Mark 138	1
P71	Hose Clamp Mark 115	3
P75	Tie Wrap M	3
P78	Insulator Sheet 300mm x 300mm	1

(1) Cut off the shaded portion of the reinforcement as shown below:

NOTE

Modify the reinforcement to avoid unnecessary contact with the intercooler.

Mark the center position of the reinforcement. Cut the reinforcement referring to the photo on the right.

Make sure to leave the holes to install the intercooler bracket.

After cutting off the shaded portions, remove burr and apply a rust prevention treatment.

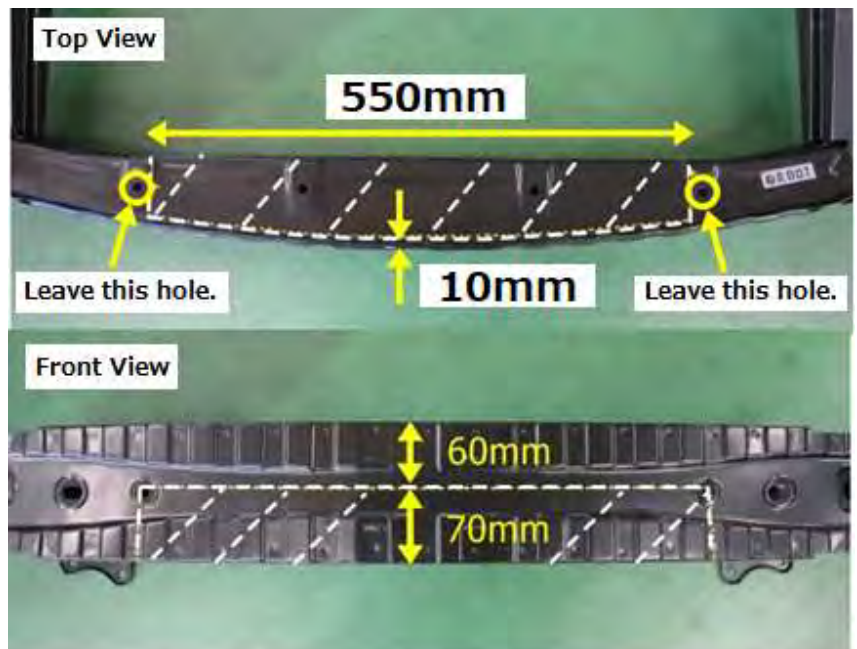

(2) Install the Flange Bolt M6 L15 from the back of the right side hole in the reinforcement. Install the Flange Nut M6 to the bolt.

- P65: Flange Nut M6 x 1
- P66: Flange Bolt M6 L15 x 1

NOTE

These bolt and nut are to install a horn. Use a magnet hand or a similar tool for easy installation.

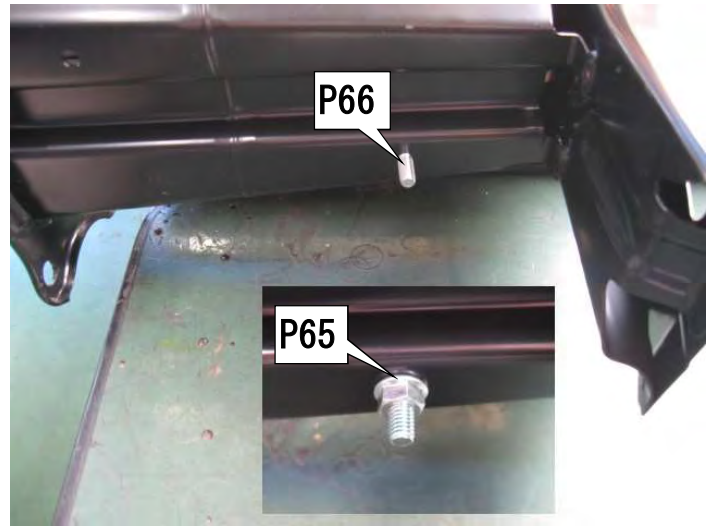

(3) Cut off the shaded portion of the front bumper energy absorber as shown in the photo on the right.

NOTE

Cut off the portion along the rib on the back.

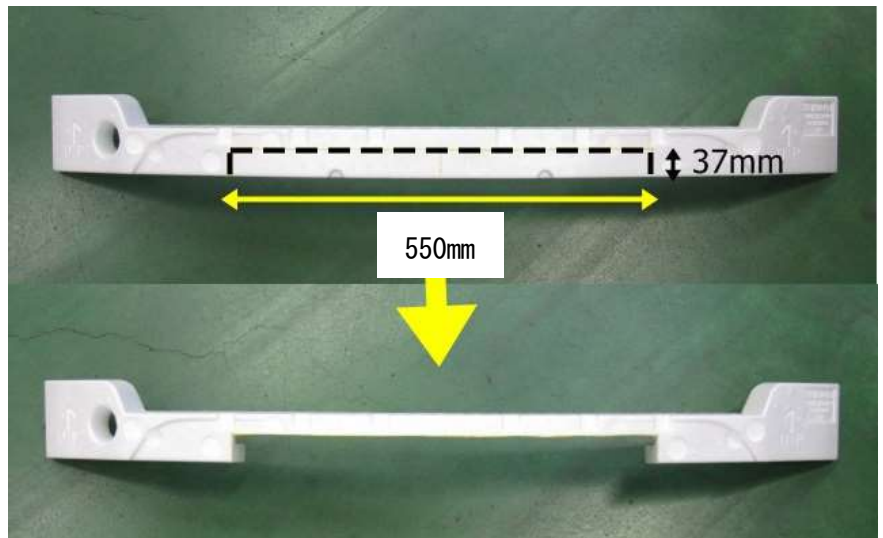

(4) Modify the front bumper bracket as shown in the photo shown on the right.

NOTE

This modification is to secure the intercooler bracket.

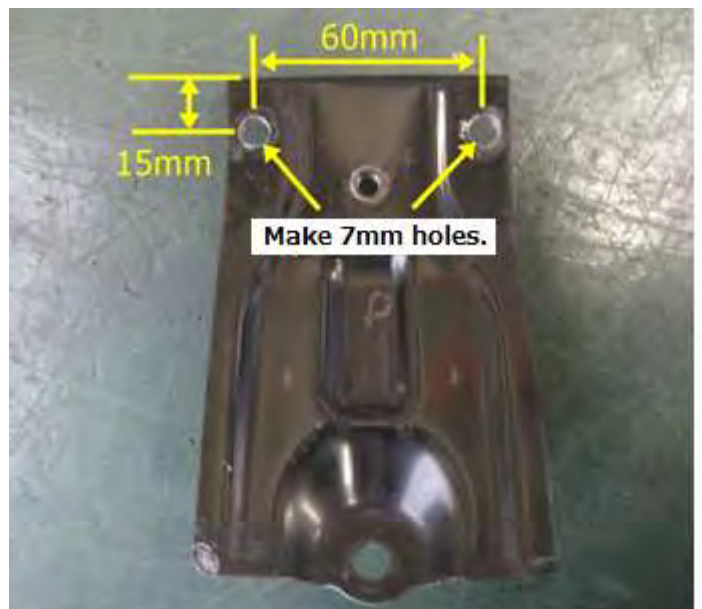

- (5) Cut the radiator support as shown in the photo on the right.

NOTE

This modification is to avoid unnecessary contact with the intercooler pipe.

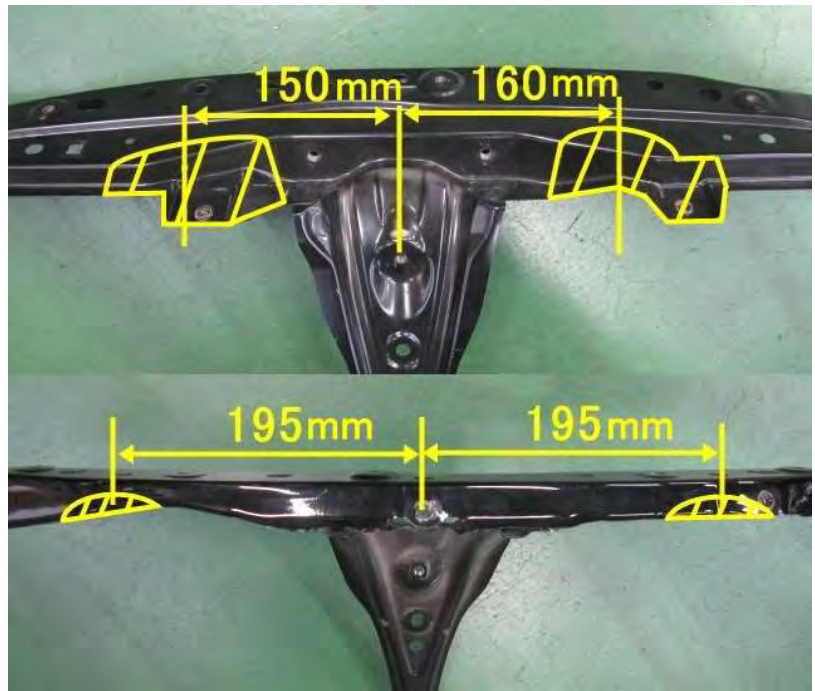

- (6) Cut the fan shroud as shown in the photos on the right side.

NOTE

This modification is to avoid unnecessary contact with the air cleaner and piping.

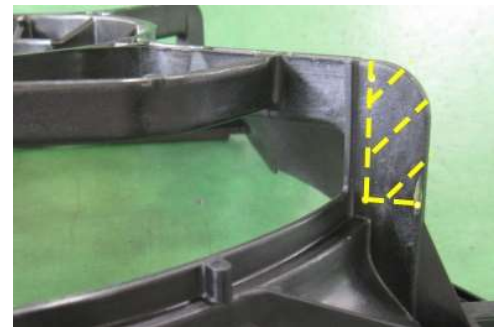

- (7) Install the modified fan shroud to the vehicle.

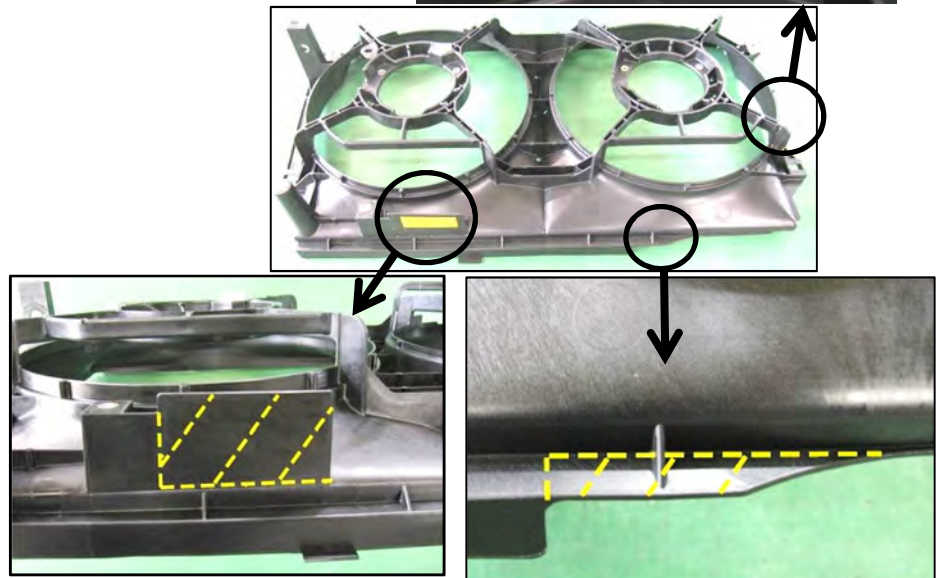

(8) Cut the Insulator Sheet 300 x 300 to an appropriate size and wrap the wire with a cut sheet.

- P78: Insulator Sheet 300mmx300mm x 1

(9) Change the electric fan wiring as shown in the photo on the right. Secure the wire using three Tie Wrap M.

- P75: Tie Wrap M x 3

NOTE

Wiring from the center of the fan shroud should be placed to the back of the radiator support that will be installed later.

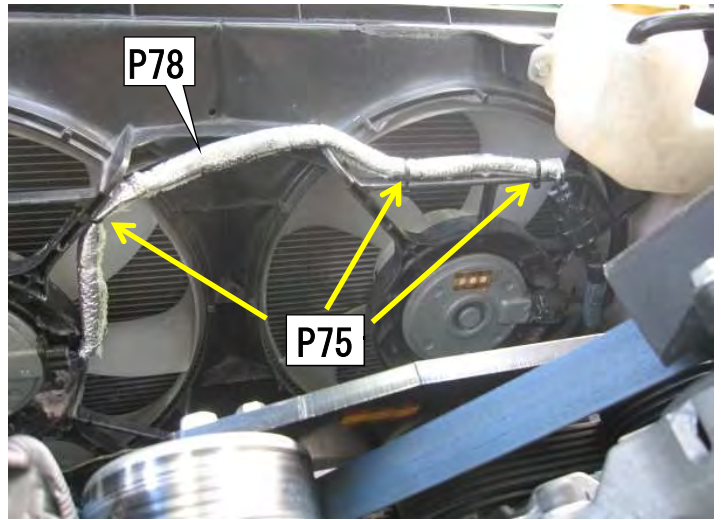

(10) Remove the oil pan from the vehicle.

(11) Drill a 17mm hole in the position indicated in the photo on the right.

NOTE

Make sure to measure from the flange edge by a ruler.

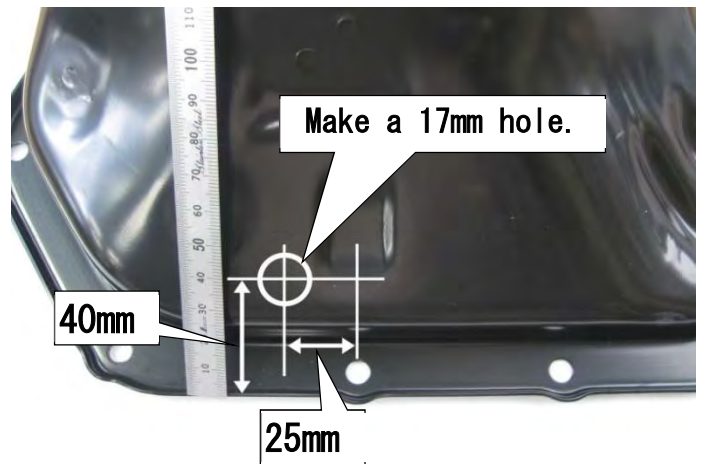

(12) Temporarily reinstall the oil pan, and temporarily install the Exhaust Manifold using the provided Gaskets.

- P2: Exhaust Manifold
- P23: Gasket

(13) Determine the installation position of the Oil Return Pipe. Mark the position or temporarily install the pipe.

- P19: Oil Return Pipe

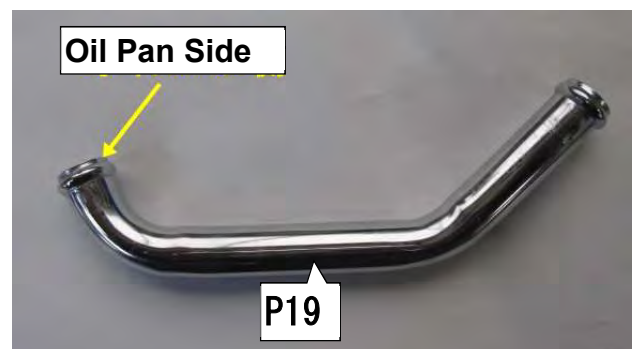

NOTE

Make sure the clearance between the exhaust manifold and Oil Return Pipe is at least 15mm.

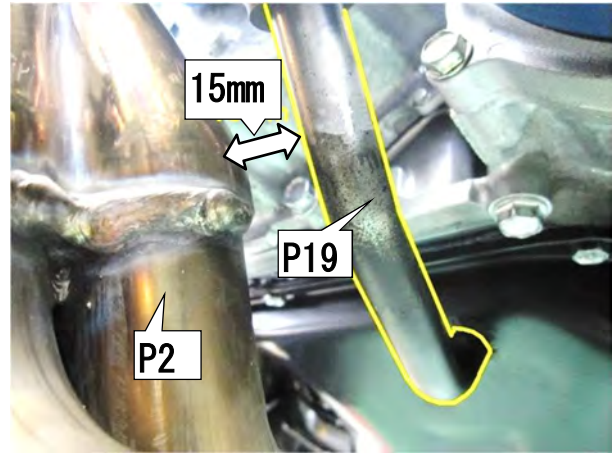

The clearance between the V-belt and pipe should be approximately 20mm, and approximately 60mm between the bolt.

Make sure to insert the Oil Return Pipe to the oil pan until the pipe end contacts the stopper.

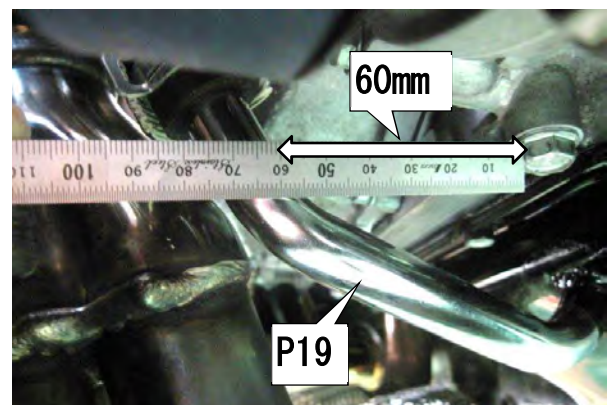
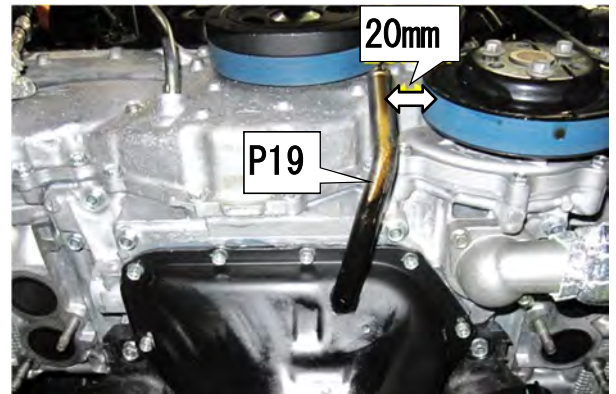

(14) Remove the oil pan. Weld the Oil Return Pipe to the oil pan.

NOTE

Weld the pipe gradually and make sure the clearance between parts during welding. Remove paint on the welding part of the oil pan using a sand-paper before welding. Carefully check the welding seam for leads.

(15) Apply a rust prevention treatment to the weld zone. After the treatment is applied and the applied zone becomes dry, clean the parts.

NOTE

Make sure to remove all foreign objects such as burr, chip, etc. to prevent engine damage.

(16) Clean the installation surface of the oil pan and engine using a scraper or a similar tool and remove oil from the surfaces. Install the oil pan using a liquid gasket 1217G.

NOTE

Reuse the stock bolt and seals.

(17) Remove the Exhaust Manifold.

(18) Remove the installation bolt from the A/C compressor.
Move the compressor slightly so there is adequate space for installation function under the intake manifold.

NOTE

Do not disconnect the piping.

(19) Remove the installation bolt from the throttle body. Move the throttle body slightly so there is adequate space for installation function under the intake manifold.

NOTE

Do not disconnect the water piping.

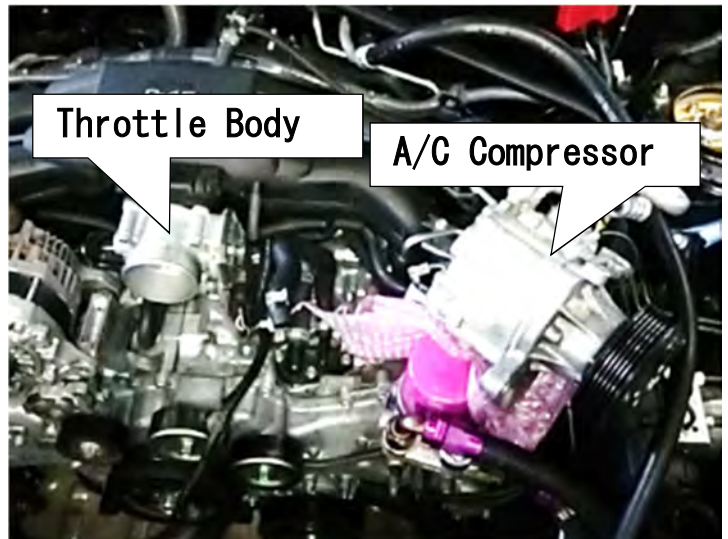

(20) Remove the canister purge solenoid from the intake manifold.
Install the Hose Clamps as shown in the diagram on the right.

- P68: Hose Clamp Mark 130 x 1
- P71: Hose Clamp Mark 115 x 3

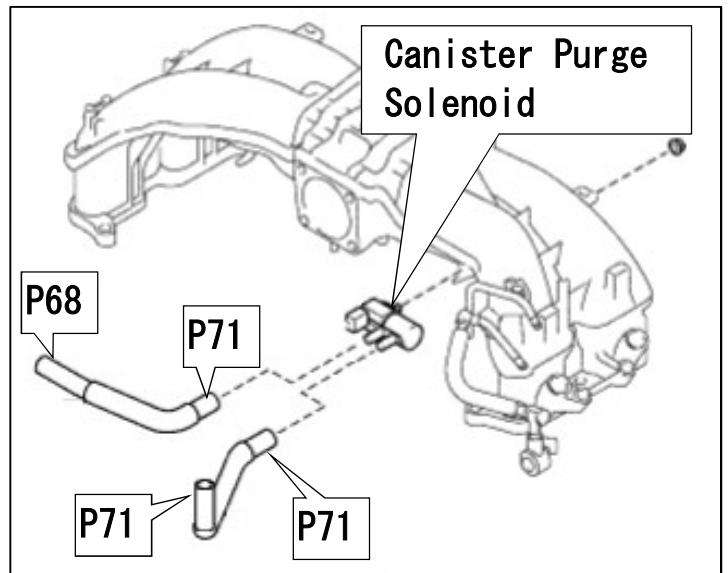

(21) Reinstall the canister purge solenoid. Place the throttle body and A/C compressor back in place.

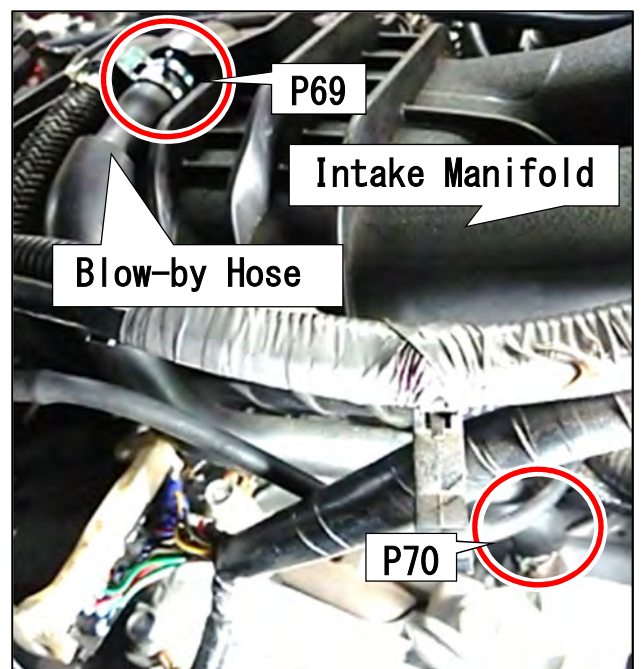

(22) Install the Hose Clamps to the blow-by hose.

- P69: Hose Clamp Mark 180 x 1
- P70: Hose Clamp Mark 138 x 1

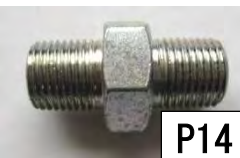

3. INSTALLATION OF OIL INLET PARTS

※Air-blow each part before installation to prevent the entry of foreign debris.

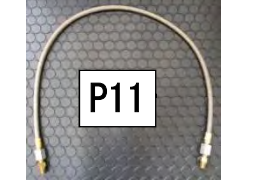
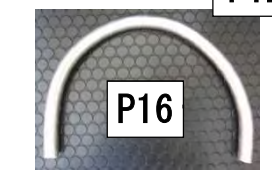
PARTS LIST			
No.	Description	QT	
P11	Oil Inlet Hose L=460mm	1	
P12	Oil Inlet Banjo	1	
P13	T-fitting PT1/8	1	
P14	Hexagon Fitting	1	
P15	Oil Line Fitting	1	
P16	Thermal Tube φ21	1	



Caution

- When assembling the oil line, do not use a seal tape. Make sure to use only minimum required amount of liquid gasket to prevent damage to the turbocharger assembly.
- Make sure to secure the oil inlet hose without excessive force on the caulking section of the oil inlet hose and bending the hose too tight. If neglected, excessive stress may be applied to the hoses by engine vibration and such which may result in leakage of oil causing vehicles fire in the worst case.

(1) Remove the oil pressure switch from the engine block.

(2) Install the Hexagon Fitting and Oil Line Fitting to the T-fitting. Apply the ThreeBond TB1324 thinly to the PT thread.

- P13: T-fitting PT1/8 x 1
- P14: Hexagon Fitting x 1
- P15: Oil Line Fitting x 1

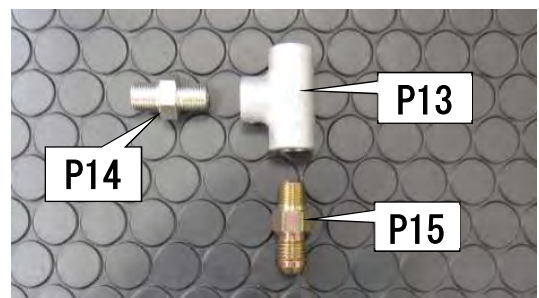

NOTE

Make sure not to overtighten the PT thread to prevent damage to other parts of the vehicle. Apply only minimum required amount of ThreeBond TB1324 so it does not run off to the oil flow line.

(3) Degrease the PT threads of the parts assembled in (2). Then install it with ThreeBond TB 1324 coating on the engine.

(4) Degrease the PT threads of the parts assembled in (1). Then install it with ThreeBond TB 1324 coating on the engine.

(5) Install the Oil Inlet Hose.

- P11: Oil Inlet Hose L=460mm x 1

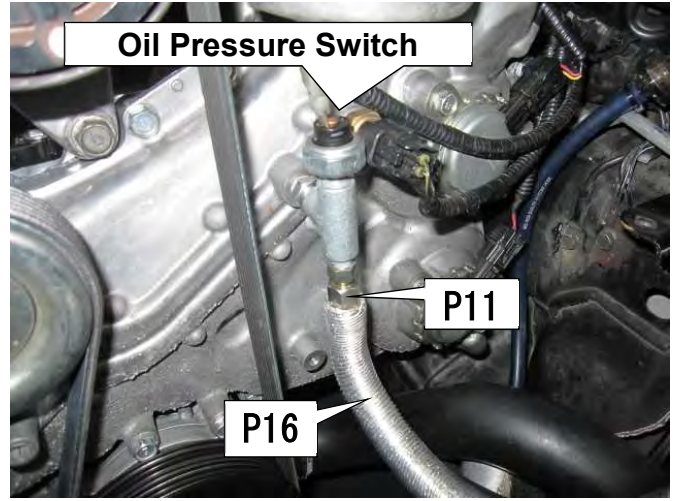

(6) Cut the provided Thermal Tube $\phi 21$ to 450mm in length. Cover the hose with the cut tube.

- P16: Thermal Tube $\phi 21$ x 1

(7) Temporarily install the Oil Inlet Banjo.

- P12: Oil Inlet Banjo x 1

NOTE

The inlet banjo will be tightened completely after the turbocharger is installed.

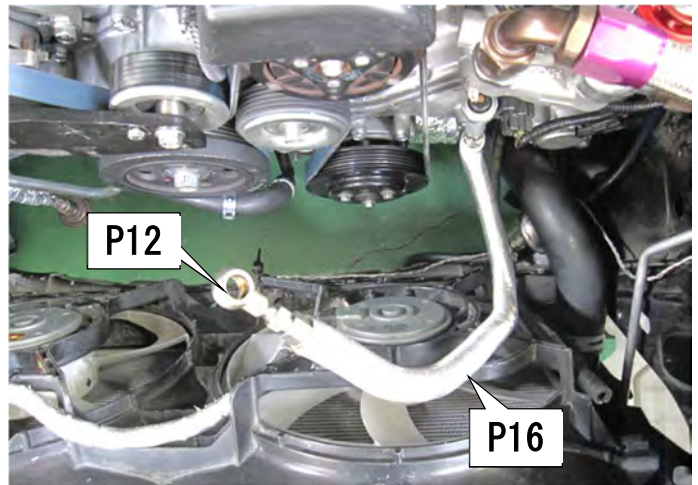

4. INSTALLATION OF TURBOCHARGER BRACKET

PARTS LIST

No.	Description	QT
P6	Turbocharger Bracket No.1	1
P7	Stepped Spacer O.D.φ20	1
P8	Spacer O.D.φ20	1
P48	Flange Bolt M10 L50 7-mark	2
P87	Flange Bolt M6 L10	1

- (1) Place a tool on the belt tensioner bolt. Loosen the belt as shown in the diagram on the right and secure it with a 3mm hexagonal wrench or a similar tool.

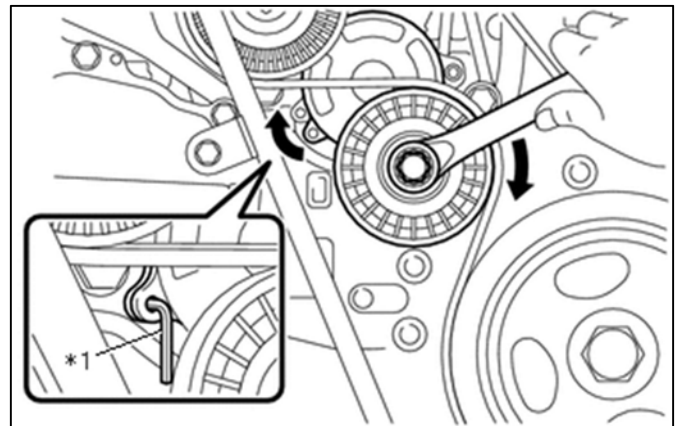

- (2) Remove the idler pulley No.1 as shown in the diagram on the right. The removed idler pulley cover (washer) will be reused later.

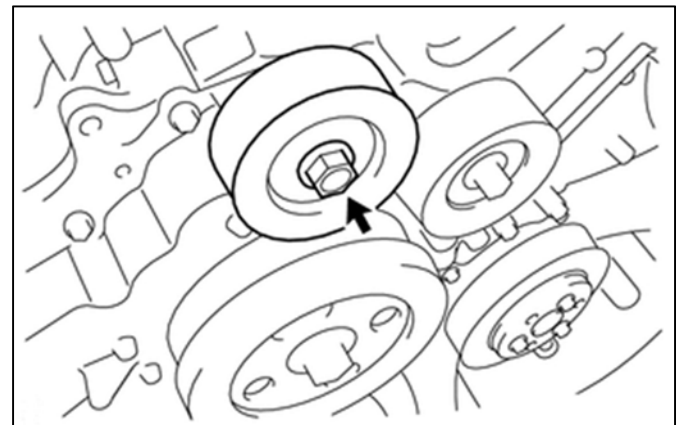

- (3) Remove the idler pulley No.2 as shown in the diagram on the right. The removed idler pulley cover (washer) will be reused later.

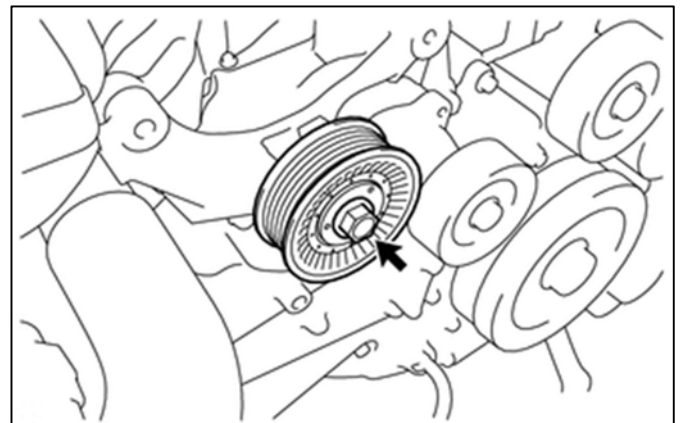

(4) Install the Turbocharger Bracket No.1, Stepped Spacer O.D. ϕ 20, Spacer O.D. ϕ 20, removed idler pulley cover, and idler pulley using the provided Flange Bolt M10 L50 7-mark.

- P6: Turbocharger Bracket No.1 x 1
- P7: Stepped Spacer O.D. ϕ 20 x 1
- P8: Spacer O.D. ϕ 20 x 1
- P48: Flange Bolt M10 L50 7-mark x 1

NOTE

Make sure to install the Stepped Spacer in a correct direction.

● **Tightening Torque : N · m (kgf·m)**

M10 : T=36 (3.67)

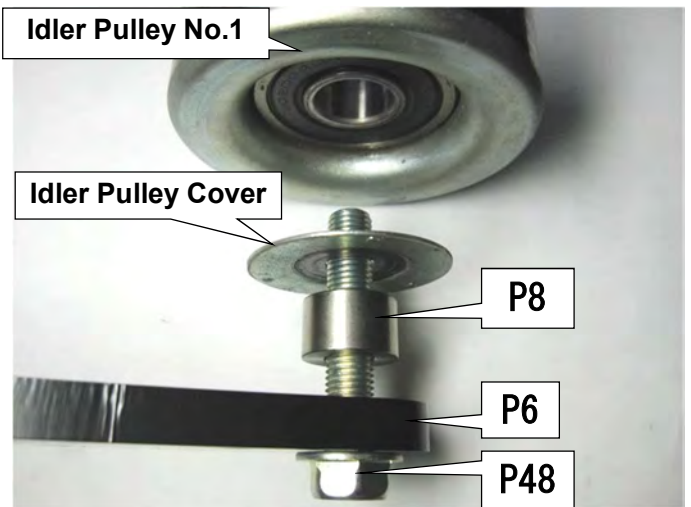
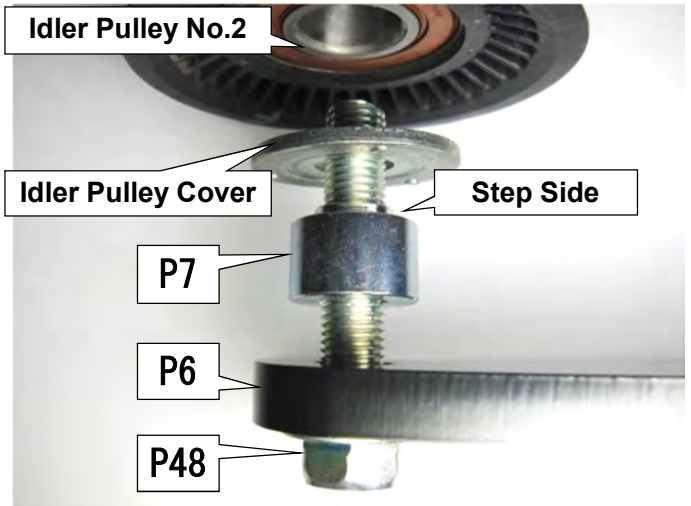

(5) Temporarily install the Flange Bolt M6 L10 as shown in the photo on the right.

- P87: Flange Bolt M6 L10 x 1

NOTE

This bolt is to install the insulator.
The bolt is installed here for easier installation of the insulator.



(6) Make sure the belt is placed on all pulleys. Remove the 3mm hexagonal wrench or a similar tool securing the belt. Make sure a proper tension is applied to the belt.



5. INSTALLATION OF EXHAUST MANIFOLD

PARTS LIST

No.	Description	QT
P2	Exhaust Manifold	1
P9	Turbocharger Bracket No.2	1
P23	Gasket	2
P30	Extension Bracket	1
P40	Hose Band #28	2
P43	Insulator $\phi 50$ L=100mm	1
P49	Hexagon Bolt M8 L15	4
P50	Flat Washer M8	4
P51	Oil Level Gauge Pipe Bracket No.1	1
P52	Oil Level Gauge Pipe Bracket No.2	1
P53	Flange Bolt M6 L10	2
P54	Flat Washer M6	2
P55	Flange Nut M6	2
P59	Stud Bolt M8 13-9-16	4
P78	Insulator Sheet 300mm x 300mm	1

(1) Install the Stud Bolt M8 13-9-16 to the Exhaust Manifold.

- P2: Exhaust Manifold x 1
- P59: Stud Bolt M8 13-9-16 x 4

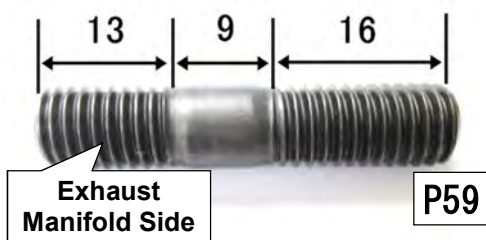

(2) Install the Insulator $\phi 50$ L=100 to the Exhaust Manifold

- P40: Hose Band #28 x 2
- P43: Insulator $\phi 50$ L=100mm x 1

NOTE

Place the insulator toward the engine side.
Install the hose band over the SUS mesh.

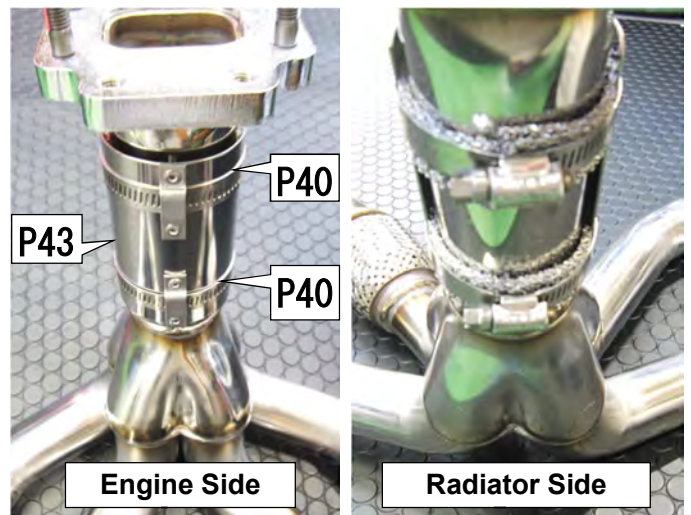

- (3) Cut the Insulator Sheet to an appropriate size as shown in the photo on the right. Wrap the radiator hose with the Insulator Sheet and secure the sheet with a wire.

- P78: Insulator Sheet 300mm x 300mm x 1

NOTE

Insulate the other parts around the exhaust manifold.

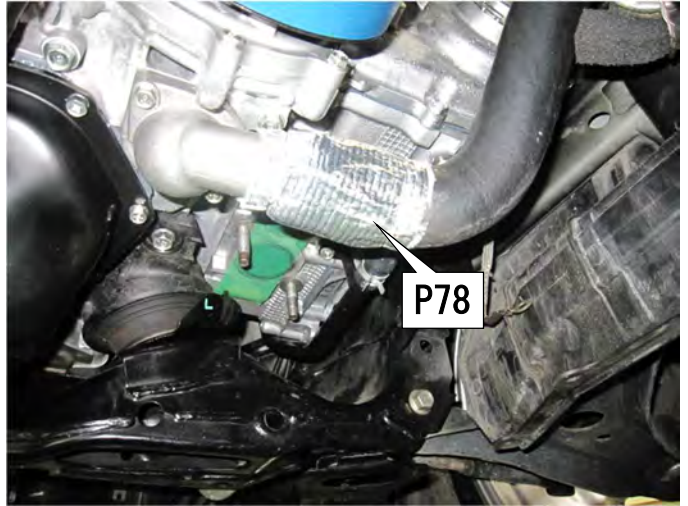

- (4) Temporarily install the Exhaust Manifold using the provided Gasket and stock nut. The extension bracket is co-tightened to the flange.

- P2: Exhaust Manifold x 1
- P23: Gasket x 2
- P30: Extension Bracket x 1

NOTE

For easier positioning of the extension bracket, temporarily install the extension bracket after installing the extension.

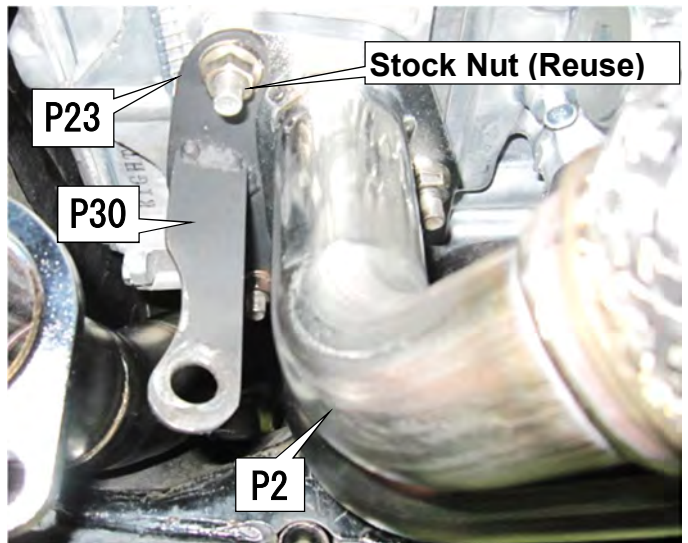

- (5) Temporarily install the Turbocharger Bracket No.2 to the flange on the turbocharger side.

- P9: Turbocharger Bracket No.2 x 1
- P49: Hexagon Bolt M8 L15 x 4
- P50: Flat Washer M8 x 4

NOTE

Do not use the flange bolt here since the bracket seat surface is narrow.

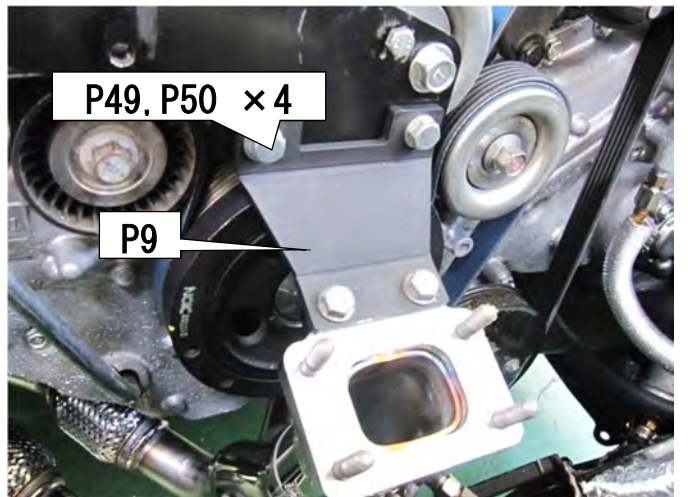

- (6) Determine the installation position of the Exhaust Manifold; then tighten the Turbocharger Bracket No.2 completely.

NOTE

Assemble the gasket to the turbine side flange of the exhaust manifold and turbocharger. Then make sure there is no interference with bracket no.2.

- (7) Remove the oil level gauge pipe for cutting.

- (8) Cut the mounting bracket of the stock oil level gauge pipe at a point about 40mm from the seat of the mounting bolt and rust-proof the cut surface. After cutting, check that there is no debris or dust inside the pipe.



- (9) Make sure that the O-ring (it is onto engine side of oil level gauge pipe) is not damaged or contaminated, apply a thin coat of fresh engine oil and attach the engine.

- (10) Co-tightened the oil level gauge pipe bracket No.1 to the alternator pulley cover with the stock bolts.

- P51 Oil Level Gauge Pipe Bracket No.1 x 1

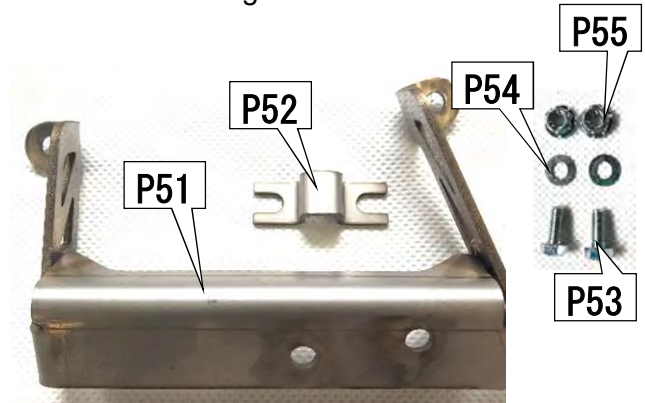

- (11) Attach the oil level gauge pipe to the oil level gauge pipe bracket No.2.

- P52 Oil Level Gauge Pipe Bracket No.2 x 1
- P53 Flange Bolt M6 L10 x 2
- P54 Flat Washer M6 x 2
- P55 Flange Nut M6 x 2



- (12) Check that the O-ring on the oil level gauge pipe has not come loose from the engine and install the level gauge.

6. ASSEMBLY OF TURBOCHARGER

※Air-blow each part before installation to prevent the entry of foreign debris.

PARTS LIST

No.	Description	QT
P1	Turbocharger Assembly	1
P17	Oil Outlet Pipe	1
P18	Gasket	1
P59	Stud Bolt M8 13-9-16	5
P66	Flange Bolt M6 L15	2

(1) Install the Oil Outlet Pipe to the Turbocharger using the provided Gasket as shown in the photo on the right.

- P1: Turbocharger Assembly x 1
- P17: Oil Outlet Pipe x 1
- P18: Gasket x 1
- P66: Flange Bolt M6 L15 x 2

NOTE

Make sure to install the oil outlet pipe in a correct direction.

- Tightening Torque : N · m (kgf·m)
M6 : T=8.5~10 (0.8~1.0)

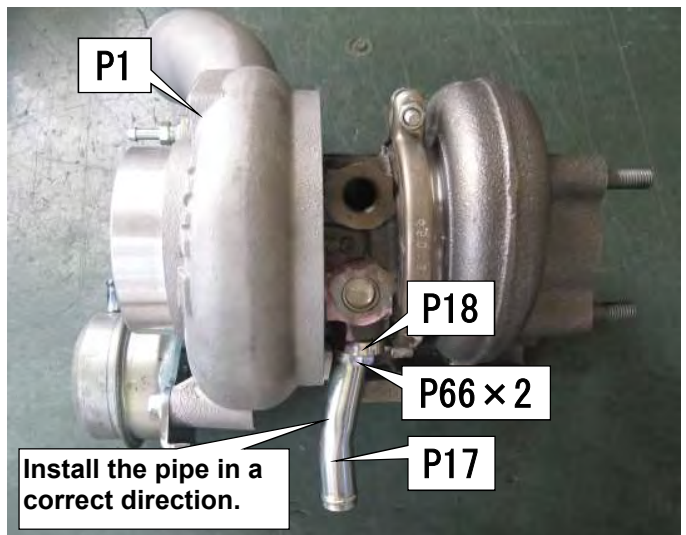

(2) Install the Stud Bolt M8 to the Turbocharger Assembly.

- P59: Stud Bolt M8 13-9-16 x 5

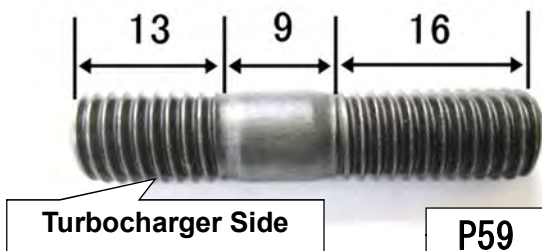

7. INSTALLATION OF TURBOCHARGER and OIL RETURN HOSE

※Air-blow each part before installation to prevent the entry of foreign debris.

PARTS LIST

No.	Description	QT
P20	Hose φ16 L=250mm	1
P21	Thermal Tube φ30 L=500mm	1
P60	Lock Nut M8	4
P67	Hose Clamp Mark 230	2
P83	Gasket	1

(1) Cut the provided Hose φ16 to 195mm in length.

- P20: Hose φ16 L=250mm x 1

(2) Install the cut Hose to the Oil Return Pipe installed in 2-(14). Secure the hose with the provided Hose Clamp Mark 230.

- P67: Hose Clamp Mark 230 x 2

NOTE

Do not completely tighten the hose clamp on the turbocharger side.

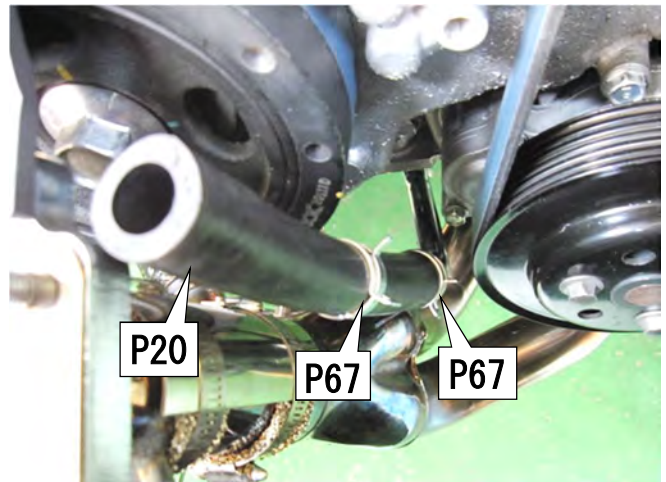

(3) Install the Turbocharger Assembly to the Exhaust Manifold using the provided Gasket and Lock Nut M8 as shown in the photo on the right.

- P60: Lock Nut M8 x 4
- P83: Gasket x 1

(The figure on the right does not have the water line pipe, because the lock nut position is not easy to understand.)

NOTE

When tightening the turbocharger with the locknut, make sure that it does not interfere with the turbocharger bracket (P9).

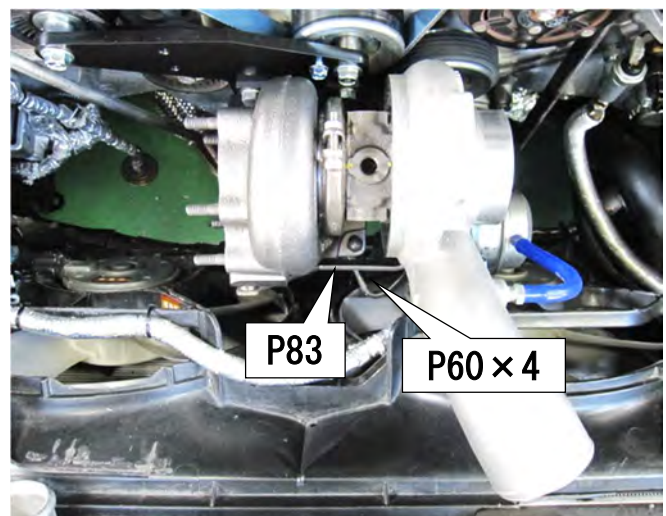

- (4) Connect the Hose from the Oil Return Pipe to the Oil Outlet Pipe from the Turbocharger Assembly. Secure the hose with the provided Hose Clamp Mark 230.

NOTE

Make sure the hose does not come in contact with the exhaust manifold, pulley, and belt.

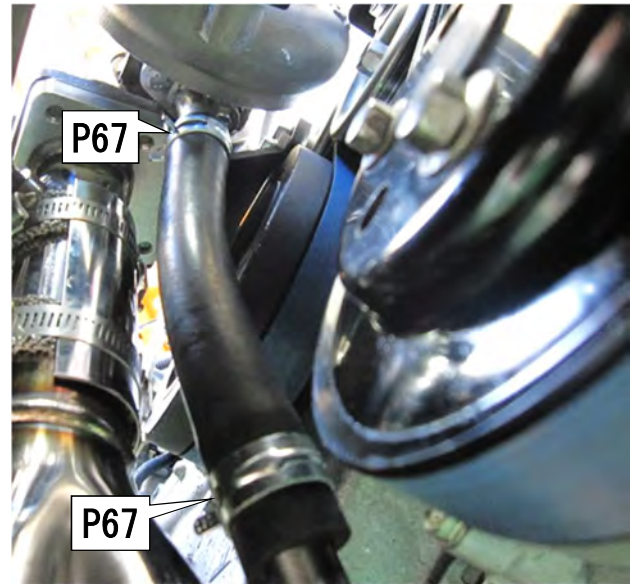

- (5) Cut the provided Thermal Tube ϕ 30 to 195mm. Make a relief cut for the hose clamp's exposed tabs.

- P21: Thermal Tube ϕ 30 L=500mm x 1

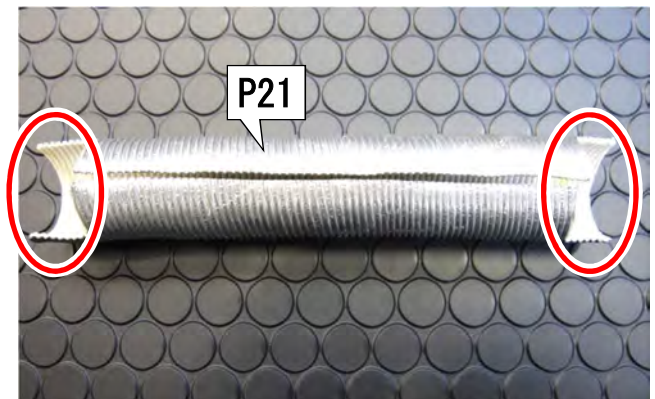

- (6) Cover the hose with the Thermal Tube modified in (5). Secure the covered hose with a wire.

NOTE

Make sure the hose does not come in contact with the exhaust manifold, pulley, and belt.

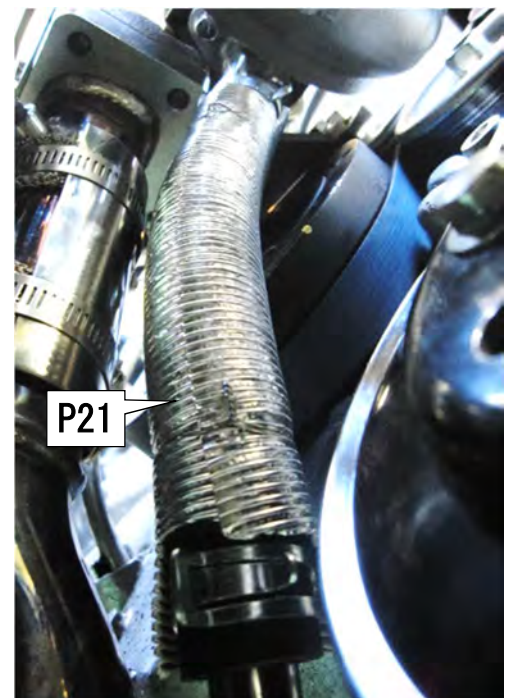

The installation of the extension pipe differs for each product.

Please check the product code you will have installed before proceeding with the installation.

8. INSTALLATION OF EXTENSION PIPE (11001-AT007)

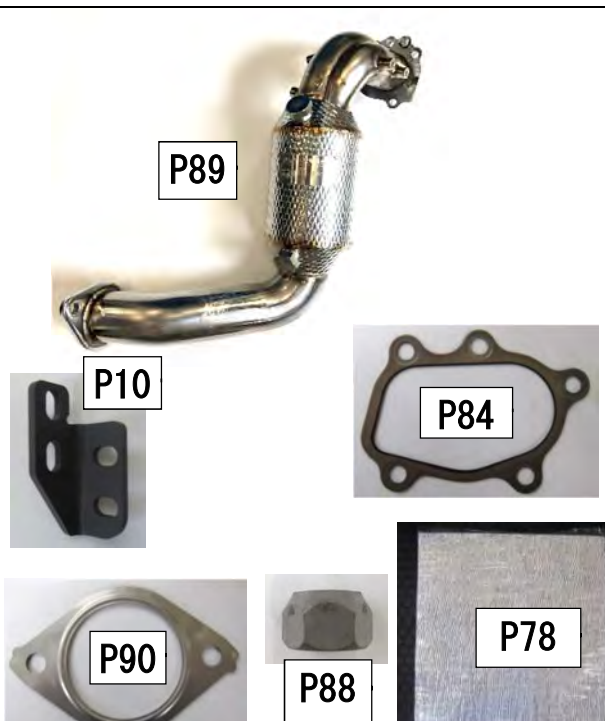
PARTS LIST				
	No.	Description	QT	
	P10	Turbocharger Bracket No.3	1	
	P49	Hexagon Bolt M8 L15	4	
	P50	Flat Washer M8	4	
	P56	Hexagon Bolt M10 L40	2	
	P57	Flat Washer M10	4	
	P58	Hexagon Nut M10	2	
	P78	Insulator Sheet 300mm×300mm	1	
	P84	Gasket	1	
	P87	Flange Bolt M6 L10	1	
	P88	Lock Nut M8	5	
	P89	Extension Pipe	1	
	P90	Gasket	1	

- (1) Cut the provided Insulator Sheet to an appropriate size. Wrap the air-fuel ratio sensor wire with the sheet and secure it with a wire.

- P78: Insulator Sheet 300mmx300mm x 1

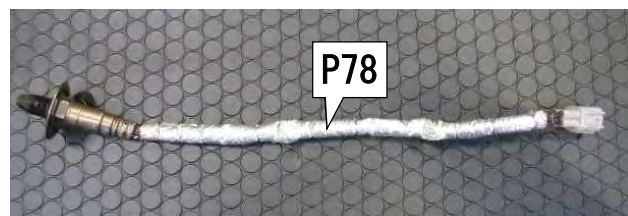

- (2) Cut the provided Insulator Sheet to an appropriate size. Wrap the camshaft position sensor wire with the sheet and secure it with a wire.

- P78: Insulator Sheet 300mmx300mm x 1

NOTE

Affix the insulator sheet to other parts around the extension. Insulator other wires or resin parts if necessary.

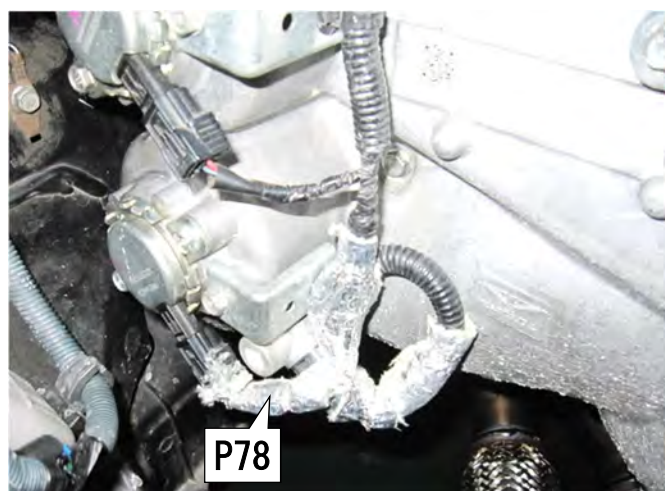

(3) Attach the extension pipe to the turbine via the gasket and attach the locknut temporarily.

- P84: Gasket x 1
- P88: Lock Nut M8 x 5
- P89: Extension Pipe x 1

(4) Attach the turbocharger bracket No.3

- P10: Turbocharger Bracket No.3 x 1
- P49: Hexagon Bolt M8 L15 x 4
- P50: Flat Washer M8 x 4
- P87 Flange Bolt M6 L10 x 1

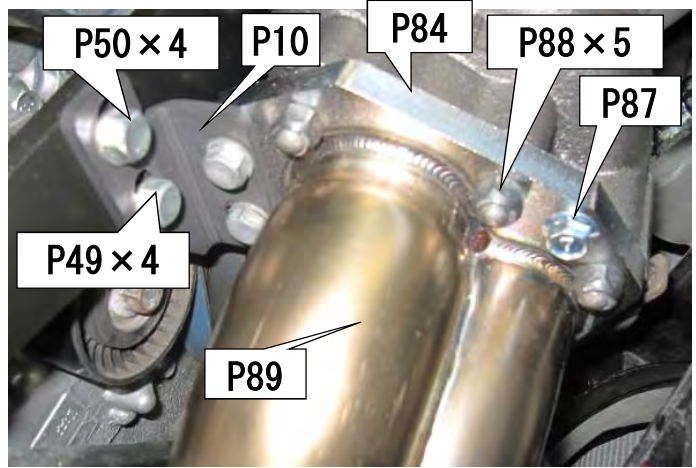

NOTE

Flange bolt M6 L10 is that for installing an insulator later work.

(5) Temporarily attach the front pipe side of the extension pipe to the joint pipe via the gasket.

At this time, co-tighten the extension bracket attached in 5-(4).

- P56: Hexagon Bolt M10 L40 x 2
- P57: Flat Washer M10 x 4
- P58: Hexagon Nut M10 x 2
- P90: Gasket x 1

(6) Tighten the M8 and M10 bolts and nuts that have been temporarily tightened in steps (3) to (5).

(7) Connect the mounting couplers to the A/F sensor and O₂ sensor.

(3) Install the provided Insulator $\phi 60$ to the Extension as shown in the photo on the right, and secure it with the provided Hose Band #40.

- P95: Extension x 1
- P98: Insulator $\phi 60$ L=120mm x 1
- P99: Hose Band #40 x 2

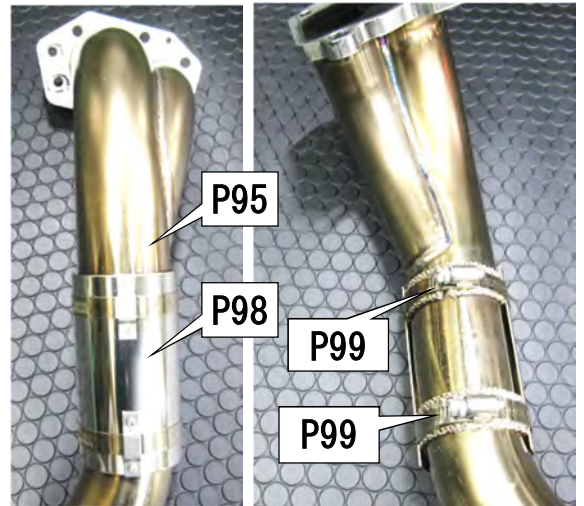

(4) Fit the extension pipe assembled in (3) with the gasket to the turbine and temporarily attach it with the locknut.

- P84: Gasket x 1
- P88: Lock Nut M8 x 5

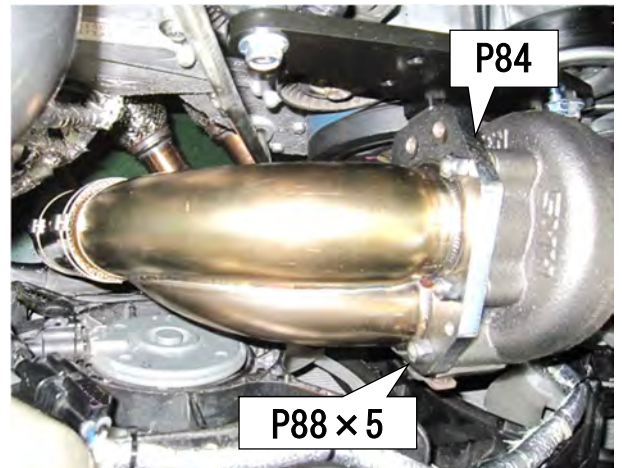

(5) Temporarily attach turbocharger bracket No. 3.

- P10: Turbocharger Bracket No.3 x 1
- P49: Hexagon Bolt M8 L15 x 4
- P50: Flat Washer M8 x 4
- P87: Flange Bolt M6 L10 x 1

NOTE

Flange bolt M6 L10 is that for installing an insulator later work.

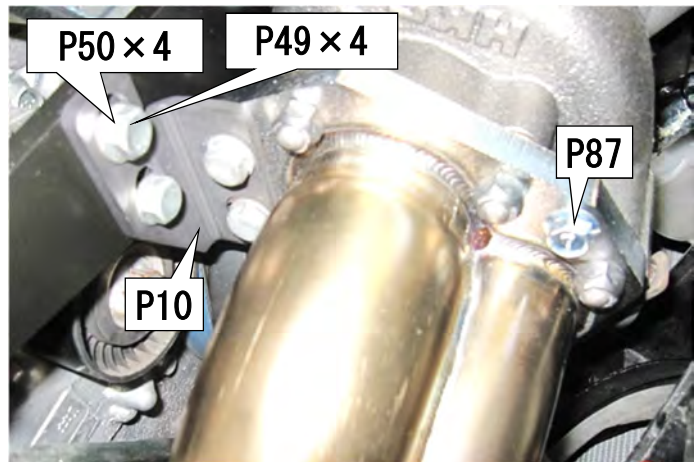

(6) Temporarily attach the front pipe side of the extension pipe to the joint pipe via the gasket. At this time, co-tighten the extension bracket attached in 5-(4).

- P56: Hexagon Bolt M10 L40 x 2
- P57: Flat Washer M10 x 4
- P58: Hexagon Nut M10 x 2
- P96: Gasket x 1

(7) Tighten the M8 and M10 bolts and nuts that have been temporarily tightened in steps (4) to (6).

(8) Connect the mounting couplers to the A/F sensor and O₂ sensor.

8. INSTALLATION OF EXTENSION PIPE (11001-KT005)

PARTS LIST

		No.	Description	QT
		P10	Turbocharger Bracket No.3	1
		P49	Hexagon Bolt M8 L15	4
		P50	Flat Washer M8	4
		P56	Hexagon Bolt M10 L40	2
		P57	Flat Washer M10	4
		P58	Hexagon Nut M10	2
		P78	Insulator Sheet 300mm×300mm	1
		P84	Gasket	1
		P87	Flange Bolt M6 L10	1
		P88	Lock Nut M8	5
		P100	Extension Pipe	1
		P101	Gasket	1
		P103	Insulator φ113 No.1	1
	P104	Insulator φ113 No.2	1	
	P105	Insulator φ60 L=120mm	1	
	P106	Hose Band #64	2	
	P107	Hose Band #40	2	

(1) Cut the provided Insulator Sheet to an appropriate size.

Wrap the air-fuel ratio sensor wire with the sheet and secure it with a wire.

- P78: Insulator Sheet 300mmx300mm x 1

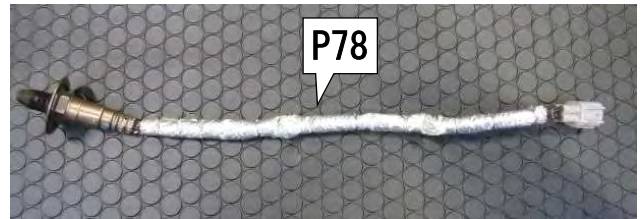

(2) Cut the provided Insulator Sheet to an appropriate size. Wrap the camshaft position sensor wire with the sheet and secure it with a wire.

- P78: Insulator Sheet 300mmx300mm x 1

NOTE

Affix the insulator sheet to other parts around the extension. Insulator other wires or resin parts if necessary.



(3) Install the provided Insulator $\phi 60$ to the Extension as shown in the photo on the right, and secure it with the provided Hose Band #40.

- P100: Extension Pipe x 1
- P105: Insulator $\phi 60$ L=120mm x 1
- P107: Hose Band #40 x 1

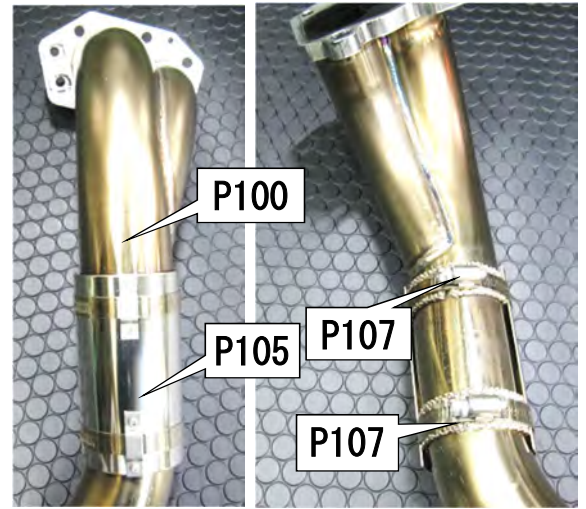

(4) Attach the A/F sensor and the O₂ sensor, attach insulators No. 1 and No. 2 to the catalyzer section of the extension pipe and fix them with a hose band.

- P103: Insulator $\phi 113$ No.1 x 1
- P104: Insulator $\phi 113$ No.2 x 1
- P106: Hose Band #64 x 1

NOTE

- The insulator No. 2 and the A/F sensor must have a clearance of about 5 mm to avoid interference.
- The gap between insulators No. 1 and No. 2 should be about 20 mm to avoid interference with the O₂ sensor.
- If the two insulators and the sensor interfere with each other, this can cause noise, so refer to the figure and assemble the insulators correctly.

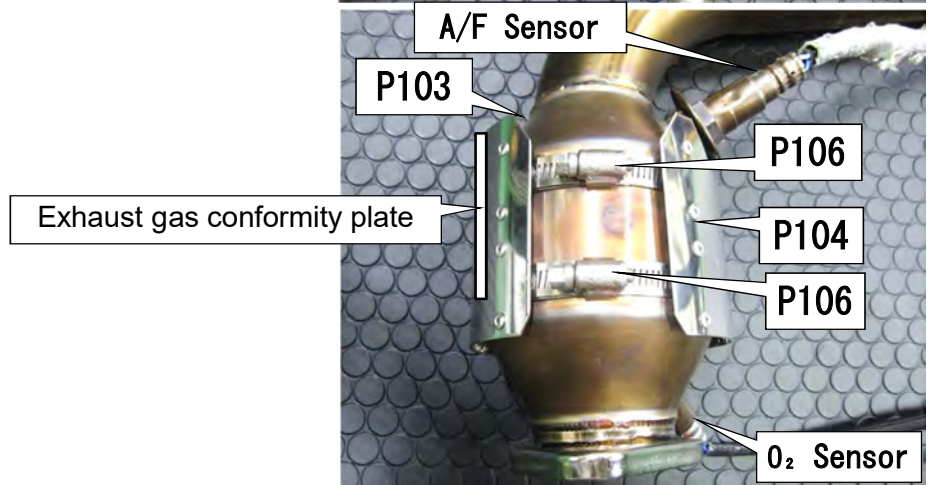
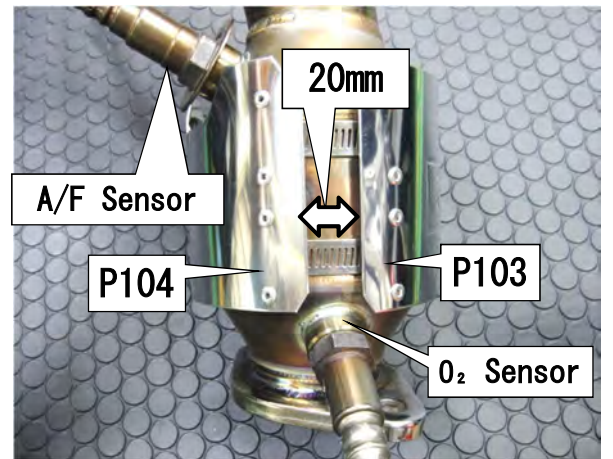
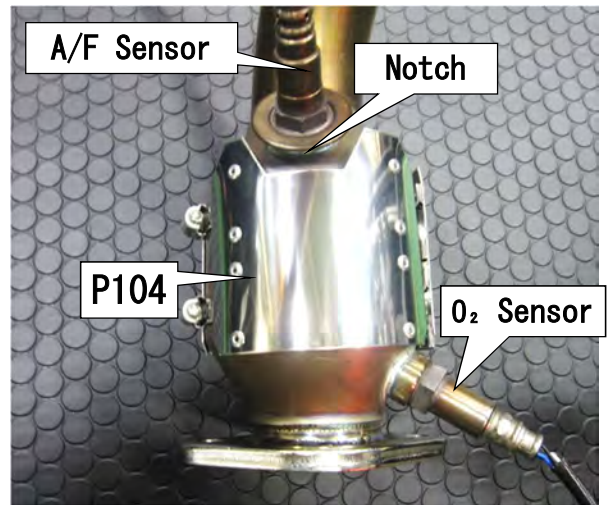

(5) Fit the extension pipe assembled in (3) and (4) with the gasket to the turbine and temporarily attach it with the locknut.

- P84: Gasket x 1
- P88: Lock Nut M8 x 5

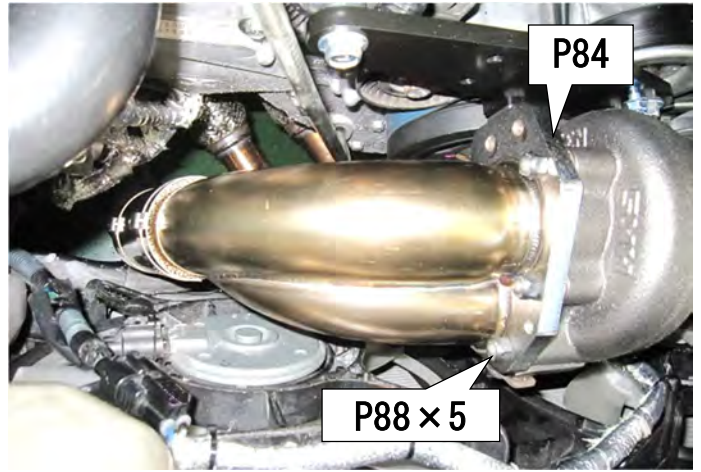

(6) Temporarily attach turbocharger bracket No. 3.

- P10: Turbocharger Bracket No.3 x 1
- P49: Hexagon Bolt M8 L15 x 4
- P50: Flat Washer M8 x 4
- P87: Flange Bolt M6 L10 x 1

NOTE

Flange bolt M6 L10 is that for installing an insulator later work.

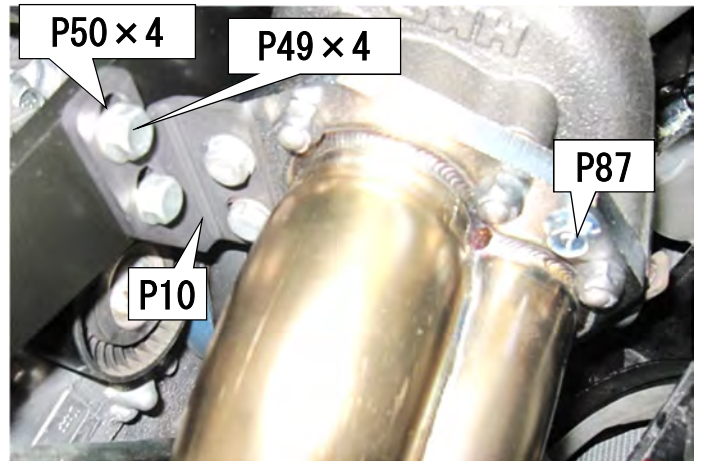

(7) Temporarily attach the front pipe side of the extension pipe to the joint pipe via the gasket. At this time, co-tighten the extension bracket attached in 5-(4).

- P56: Hexagon Bolt M10 L40 x 2
- P57: Flat Washer M10 x 4
- P58: Hexagon Nut M10 x 2
- P101: Gasket x 1

(8) Tighten the M8 and M10 bolts and nuts that have been temporarily tightened in steps (5) to (7).

(9) Connect the mounting couplers to the A/F sensor and O₂ sensor.

9. INSTALLATION OF THE CAM POSITION SENSOR INSULATOR

PARTS LIST

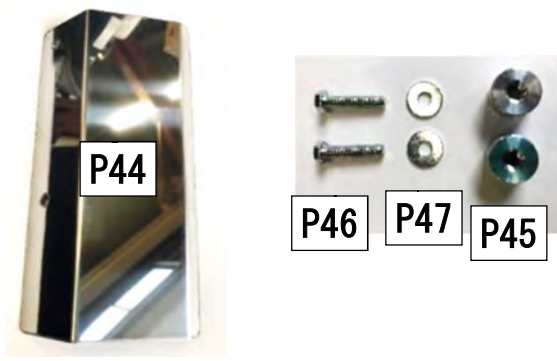
	No.	Description	QT
		P44	Insulator
	P45	Spacer (φ20-M8 L=15mm)	2
	P46	Cap Bolt M6 L=30	2
	P47	Flat Washer M6 Large Diameter	2

(1) Remove the tow bolts from the cam position wiring bracket and co-tighten the insulator to the wiring bracket.

- P44: Insulator x 1
- P45: Spacer (φ20-M8 L=15mm) x 2
- P46: Cap Bolt M6 L=30 x 2
- P47: Flat Washer M6 Large Diameter x 2

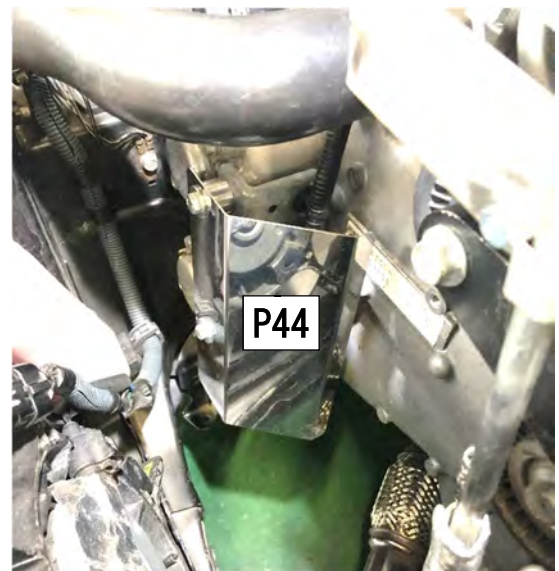

NOTE

When mounting, it is easier to make a temporary assembly as shown in the figure below.

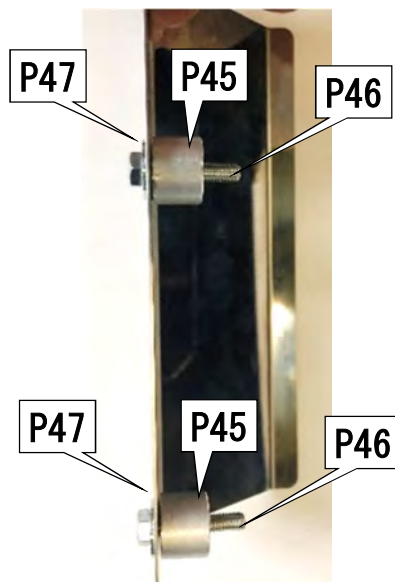

10. INSTALLATION OF TURBUCHARGER INSULATOR PARTS

PARTS LIST

No.	Description	QT
P22	Hose $\phi 8$ L=1250mm	1
P68	Hose Clamp Mark 130	2
P75	Tie Wrap M	3
P79	Water Line Banjo No.1	1
P80	Water Line Banjo No.2	1
P81	Banjo Bolt M12 P1.5	3
P82	Copper Washer $\phi 12 \times \phi 17$	6
P87	Flange Bolt M6 L10	2
P91	Insulator $\phi 100$ No.1 (11001-AT007)	1
P92	Insulator $\phi 100$ No.2 (11001-AT007)	1
P93	Flange Bolt M6 L10 (11001-AT007)	4
P97-102	Insulator No.1 (11001-KT003,11001-KT005)	1

- (1) Disconnect the water line hose that is connected from the side of the throttle to the engine rear side from the engine rear side. Cut the hose as shown in the photo on the right. Route the hose under the intake manifold to the turbine side.

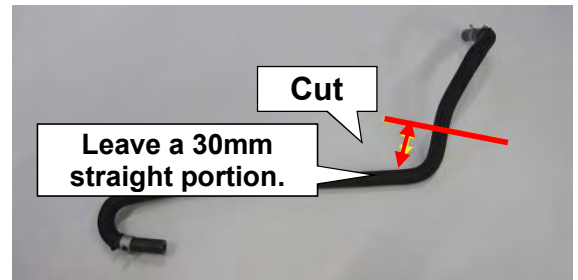

- (2) Attach water line banjo No.1 to turbocharger Assy. Use the banjo bolt M12 and copper washer to attach

- P79: Water Line Banjo No.1 x 1
- P81: Banjo Bolt M12 P1.5 x 1
- P82: Copper Washer $\phi 12 \times \phi 17$ x 2

● Tightening Torque : N · m (kgf · m)
M12 : T=17~23 (1.8~2.4)

- (3) Connect the hose removed in (1) and the Water Line Banjo No.1 as shown in the photo on the right. Reuse the stock hose clamp.

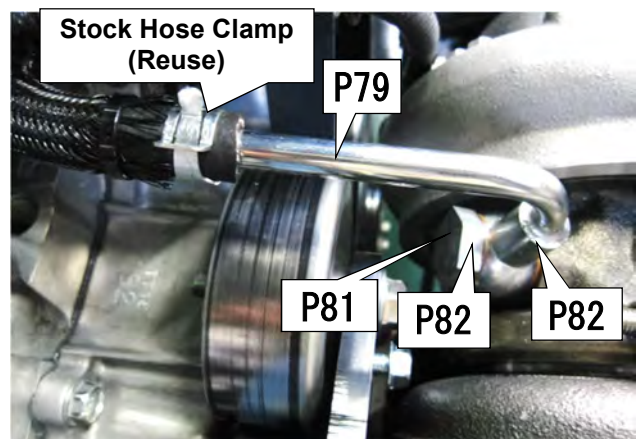

(4) Install the Water Line Banjo No.2 to the turbocharger using the provided Banjo Bolt M12 and Copper Washer $\phi 12 \times \phi 17$.

- P80: Water Line Banjo No.2 x 1
- P81: Banjo Bolt M12 P1.5 x 1
- P82: Copper Washer $\phi 12 \times \phi 17$ x 2

● Tightening Torque : N · m (kgf · m)
M12 : T=17~23 (1.8~2.4)

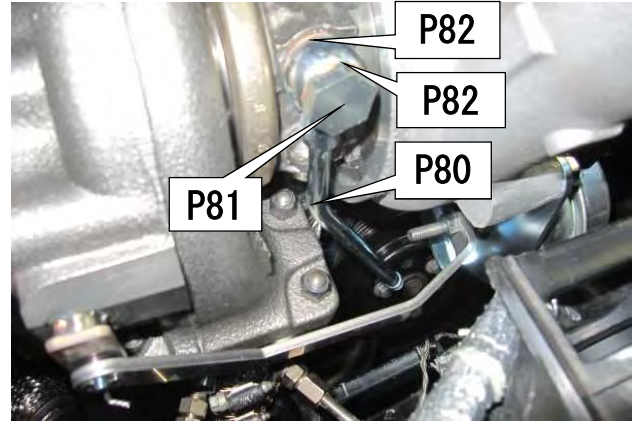

(5) Cut the provided Hose $\phi 8$ to 1200mm in length. Connect the Water Line Banjo No.2 with the water line hose removed in (1). Secure the hose with the provided Hose Clamp Mark 130 as shown in the photo on the right.

- P22: Hose $\phi 8$ L=1250mm x 1
- P68: Hose Clamp Mark 130 x 2

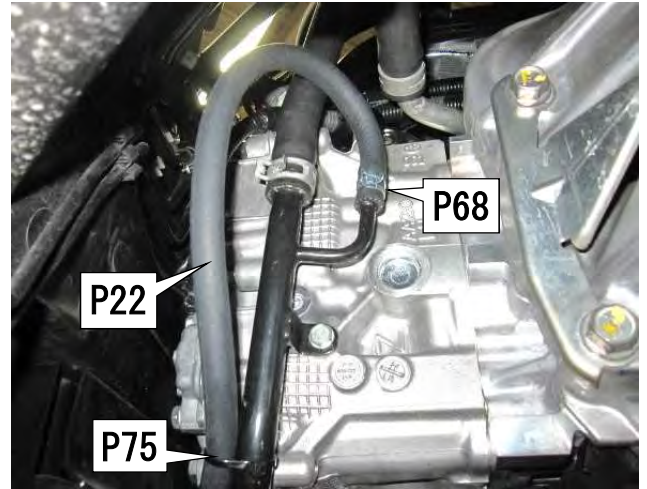

(6) Secure the hose with the provided Tie Wrap M.

- P75: Tie Wrap M x 3

NOTE

Make sure the hose $\phi 8$ does not come in contact with any rotating part such as a belt, the engine and/or shroud.



(7) Install the oil inlet hose to the turbocharger assembly as shown in the figure.

- P81: Banjo Bolt M12 P1.5 x 1
- P82: Copper Washer $\phi 12 \times \phi 17$ x 2

● Tightening Torque : N · m (kgf · m)
M12 : T=17~23 (1.8~2.4)

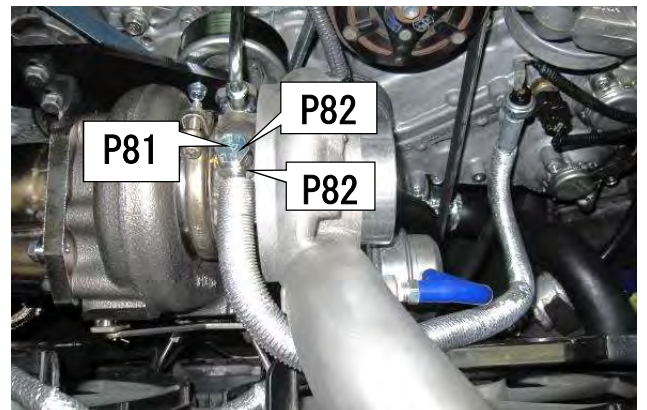

(8) Install insulator no. 2 only for 11001-AT007.

- P92: Insulator ϕ 100 No.2 x 1
- P93: Flange Bolt M6 L10 x 3

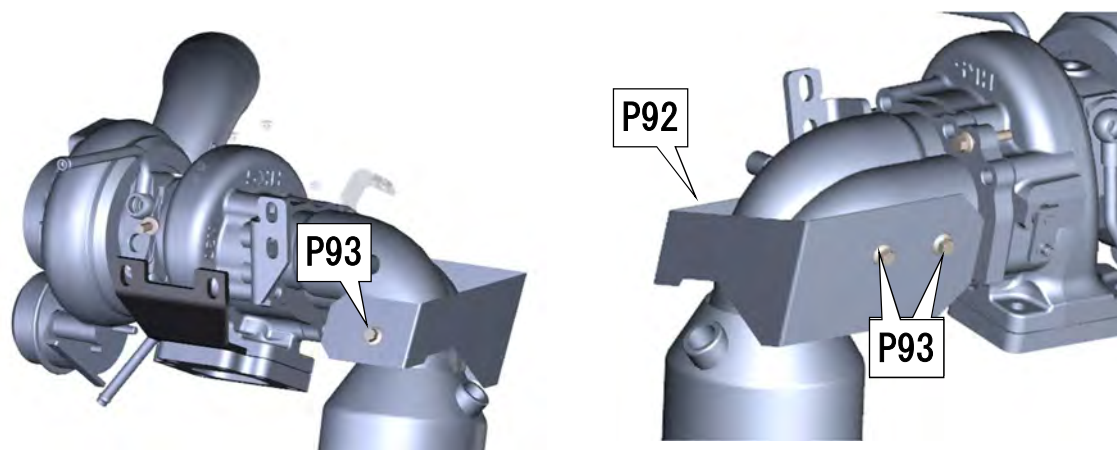

(9) Insert the Insulator into the Flange Bolt M6 L10 temporarily installed in section 4 and section 8 and tighten the bolts.

- P91: Insulator φ100 No.1 (11001-AT007) x 1
- P93: Flange Bolt M6 L10 (11001-AT007) x 1
- P97: Insulator No.1 (11001-KT003) x 1
- P102: Insulator No.1 (11001-KT005) x 1

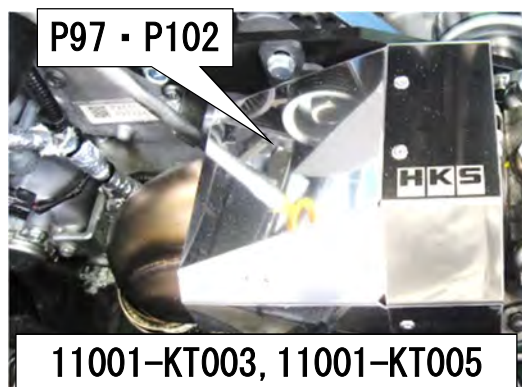
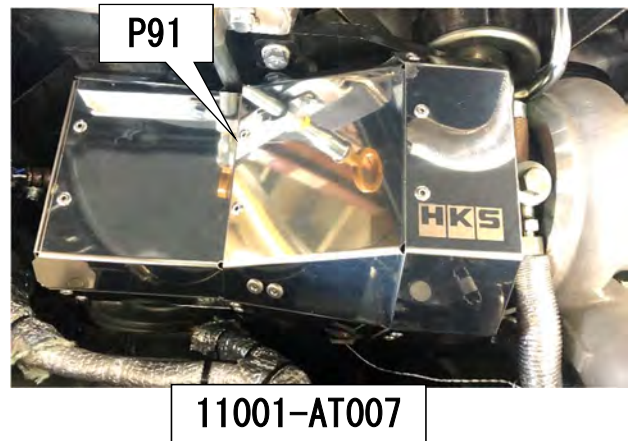
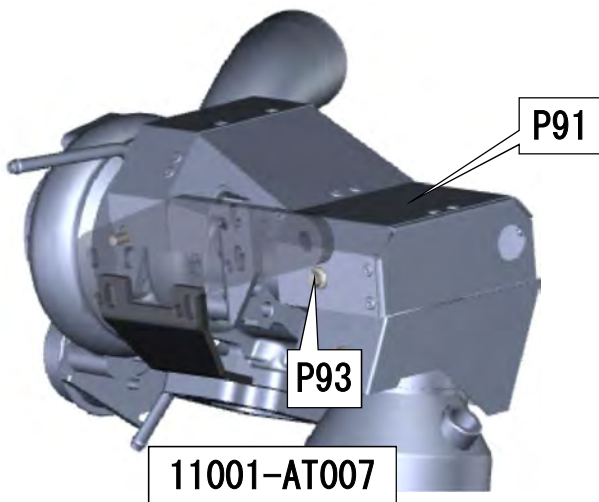
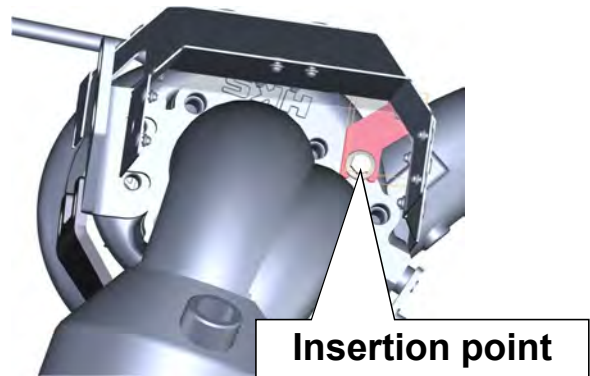
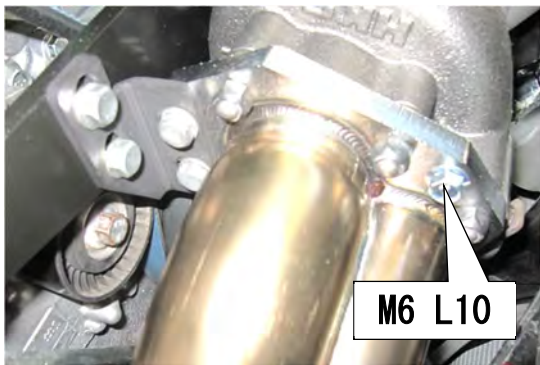
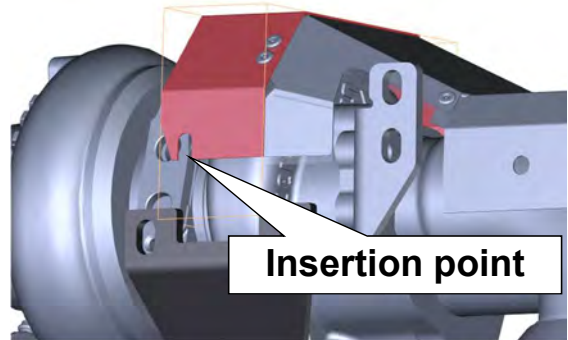
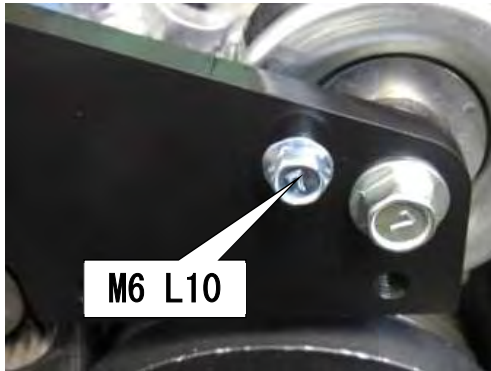

11. INSTALLATION OF AIR CLEANER and SUCTION PIPE

PARTS LIST

No.	Description	QT
P3	Suction Pipe $\phi 80$	1
P31	Air Cleaner	1
P32	Air Cleaner Bracket No.1	1
P33	Air Cleaner Bracket No.2	1
P34	Silicone Hose $\phi 80$	2
P37	Hose Band #52	4
P41	Hose $\phi 12$ L=200mm	1
P42	Joint Pipe $\phi 12$	1
P65	Flange Nut M6	1
P66	Flange Bolt M6 L15	1
P69	Hose Clamp Mark 180	2

- (1) Temporarily install the Air Cleaner Bracket No.1 and No.2 using the provided Flange Bolt M6 L15 and Flange Nut M6. Temporarily install these brackets to the vehicle body using a stock bolt. Place the Air Cleaner on the brackets and determine the bracket installation position; then, tighten the bolt and nut completely.

- P32: Air Cleaner Bracket No.1 x 1
- P33: Air Cleaner Bracket No.2 x 1
- P65: Flange Nut M6 x 1
- P66: Flange Bolt M6 L15 x 1

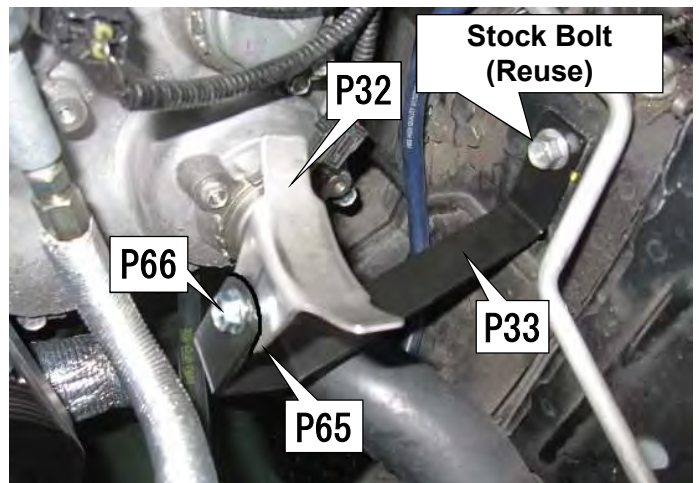

(2) Connect the Air Cleaner to the Suction Pipe using the provided Silicone Hose $\phi 80$. Secure the hose with the provide Hose Band #52.

- P3: Suction Pipe $\phi 80 \times 1$
- P31: Air Cleaner $\times 1$
- P34: Silicone Hose $\phi 80 \times 2$
- P37: Hose Band #52 $\times 4$

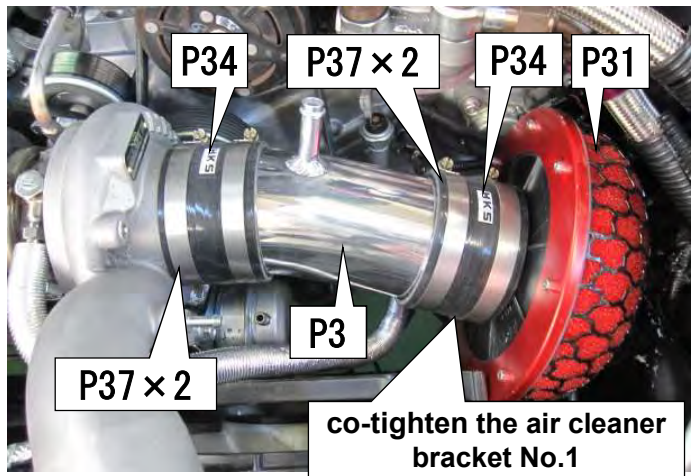

NOTE

Make sure the air cleaner does not come in contact with any other parts of the vehicle. Adjust the position of the air cleaner bracket if the air cleaner comes in contact with any other parts of the vehicle.

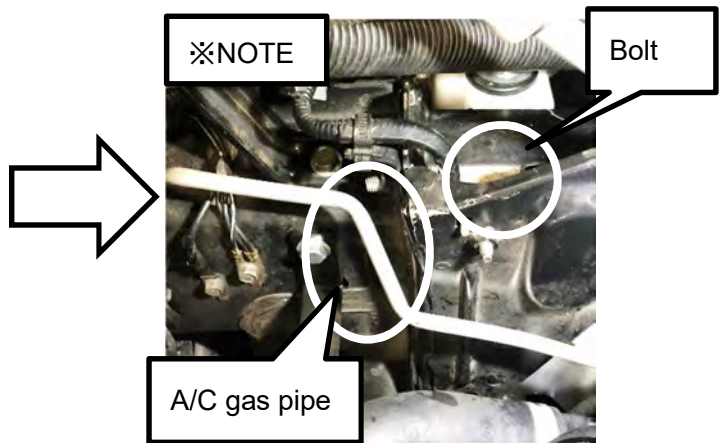

(3) Cut the Hose $\phi 12$ to 150mm in length.

- P41: Hose $\phi 12 \text{ L}=200\text{mm} \times 1$

(4) Relocate the stock blow-by hose to the left side of the A/C compressor. Connect the Hose $\phi 12$ cut in (3) to the Joint Pipe. Secure the pipe with the provided Hose Clamp Mark 180 and stock hose clamp as shown in the photo on the right.

- P42: Joint Pipe $\phi 12 \times 1$
- P69: Hose Clamp Mark 180 $\times 1$

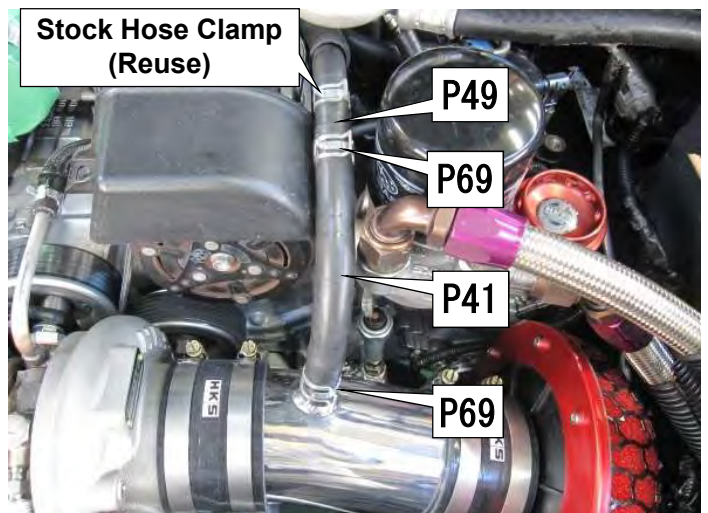





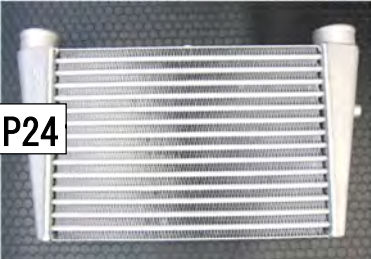

(5) Connect the Hose $\phi 12$ from the Joint Pipe to the Suction Pipe. Secure the hose using the provided Hose Clamp Mark 180.

- P69: Hose Clamp Mark 180 $\times 1$

12. INSTALLATION OF INTERCOOLER

PARTS LIST

		No.	Description	QT
		P24	Intercooler	1
		P25	Intercooler Bracket No.1	1
		P26	Intercooler Bracket No.2	1
		P27	Intercooler Bracket No.3	1
		P28	Intercooler Bracket No.4	1
		P29	Spacer O.D.φ16	2
		P61	Flange Bolt M8 L10	1
		P62	Flange Bolt M8 L15	5
		P63	Flange Nut M8	2
		P64	Flange Bolt M6 L35	2
		P65	Flange Nut M6	2

- Install the stock reinforcement modified in the section 2 and front bumper bracket.
- Insert the provided Spacer O.D.φ16 between the front bumper bracket and Intercooler Bracket No.3. Install the brackets using the Flange Bolt M6 L35 and Flange Nut M6.

- P27: Intercooler Bracket No.3 x 1
- P29: Spacer O.D.φ16 x 2
- P61: Flange Bolt M8 L10 x 1
- P64: Flange Bolt M6 L35 x 2
- P65: Flange Nut M6 x 2

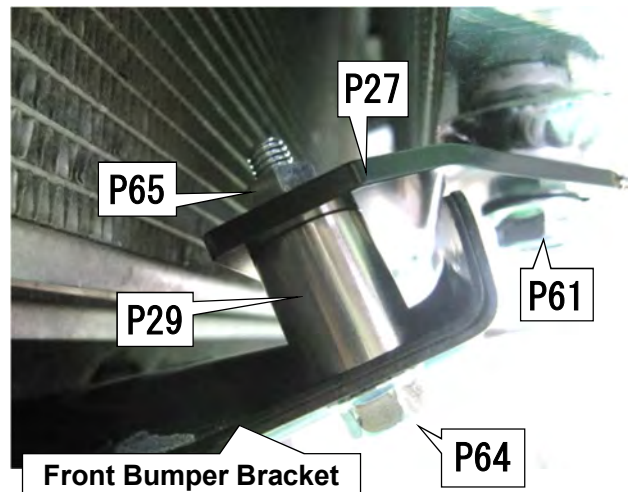

- Temporarily install the Intercooler Bracket No.1 and No.2 using the Flange Bolt M8 L15 and Flange Nut M8.

- P25: Intercooler Bracket No.1 x 1
- P26: Intercooler Bracket No.2 x 1
- P62: Flange Bolt M8 L15 x 2
- P63: Flange Nut M8 x 2

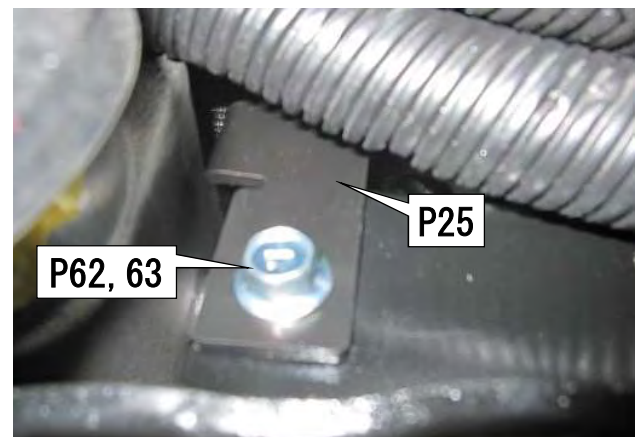

(4) Temporarily install the Intercooler.
To install the intercooler, use the Flange Bolt M8 L15 for the side of the Intercooler, and use the Flange Bolt M8 L10 for the lower side.

- P61: Flange Bolt M8 L10 x 1
- P62: Flange Bolt M8 L15 x 2

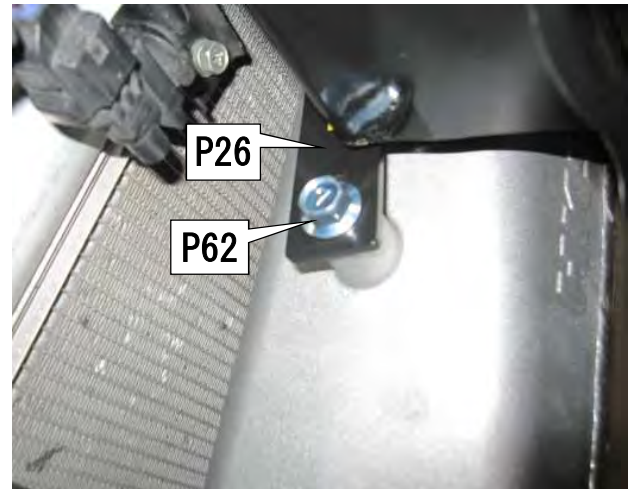
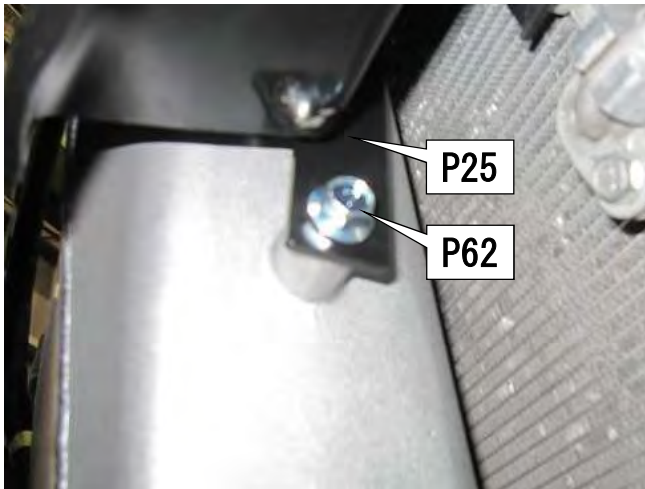
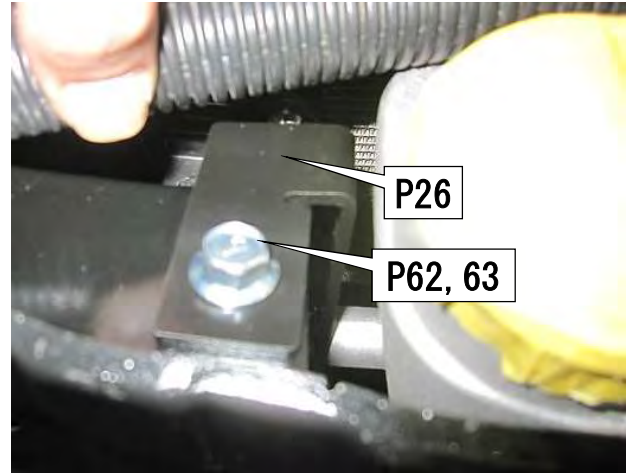

(5) Tighten all bolts completely after making sure the Intercooler does not come in contact with any other parts of the vehicle.

NOTE

Make sure to install the intercooler horizontally by adjusting the bolt position within the oval-shaped bolt hole.

(6) Install the Intercooler Bracket No.4 using the Flange Bolt M8 L15.

- P28: Intercooler Bracket No.4 x 1
- P62: Flange Bolt M8 L15 x 1

NOTE

The hole in the center of the Intercooler Bracket No.4 is to install the oil cooler kit that is available separately.

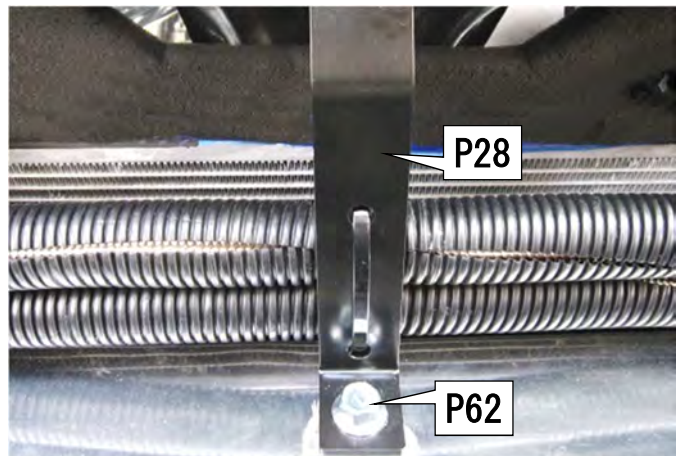

13. INSTALLATION OF PIPING

PARTS LIST

No.	Description	QT
P4	Intercooler Pipe $\phi 60$	2
P5	Chamber Pipe $\phi 70$	1
P35	Silicone Hose $\phi 60$	4
P36	Silicone Hose $\phi 70$	1
P38	Hose Band #48	2
P39	Hose Band #40	8
P73	Button Bolt M4 L10	2
P78	Insulator Sheet 300mm \times 300mm	1

- (1) Install the Intercooler Pipe using the provided Silicone Hose $\phi 60$ and Hose Band #40.

- P4: Intercooler Pipe $\phi 60$ x 1
- P35: Silicone Hose $\phi 60$ x 2
- P39: Hose Band #40 x 4

NOTE

Cut off the portion of the stock radiator sponge where comes in contact with the pipe.

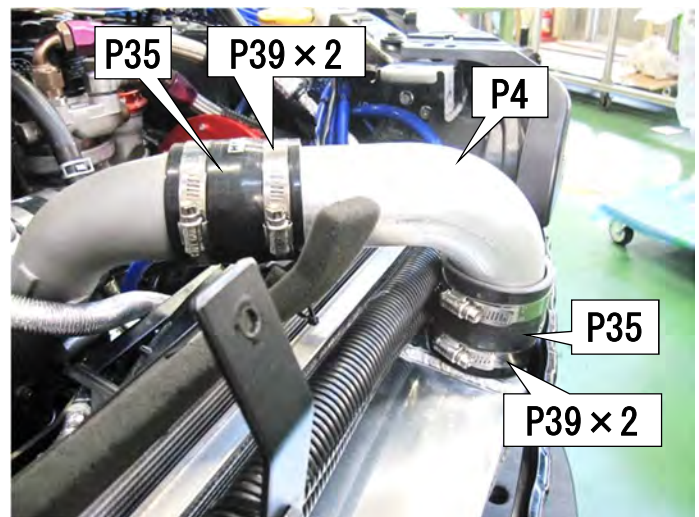

- (2) Install the Intercooler Pipe and Chamber Pipe using the provided Silicone Hose $\phi 60$ and Hose Band #40. Use the Silicone Hose $\phi 70$ for the throttle side and Hose Band #48.

- P4: Intercooler Pipe $\phi 60$ x 1
- P5: Chamber Pipe $\phi 70$ x 1
- P35: Silicone Hose $\phi 60$ x 2 (I/C side)
- P36: Silicone Hose $\phi 70$ x 1 (Throttle side)
- P38: Hose Band #48 x 2
- P39: Hose Band #40 x 4

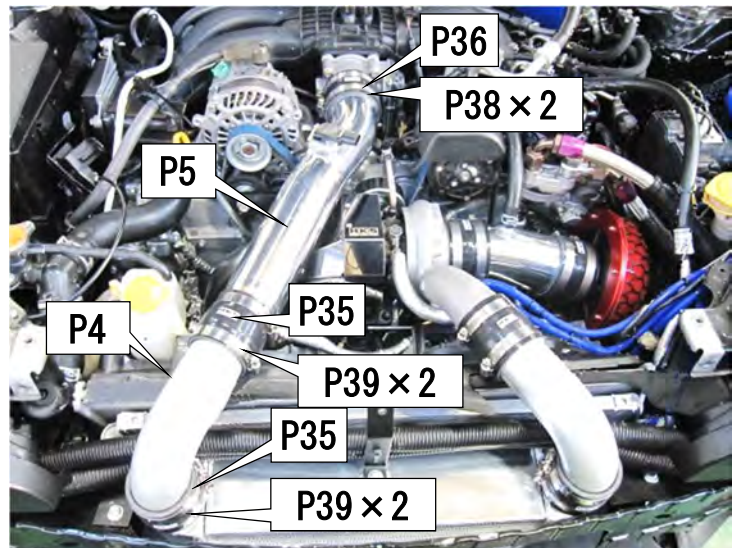

(3) Cut the Insulator Sheet to an appropriate size. Wrap the air-flow sensor wire with the Insulator Sheet and secure the wire with a wire as shown in the photo on the right.

- P78: Insulator Sheet 300mm×300mm x 1

(4) Install the air-flow sensor to the Chamber Pipe using the provided Button Bolt M4 L10.

- P73: Button Bolt M4 L10 x 2

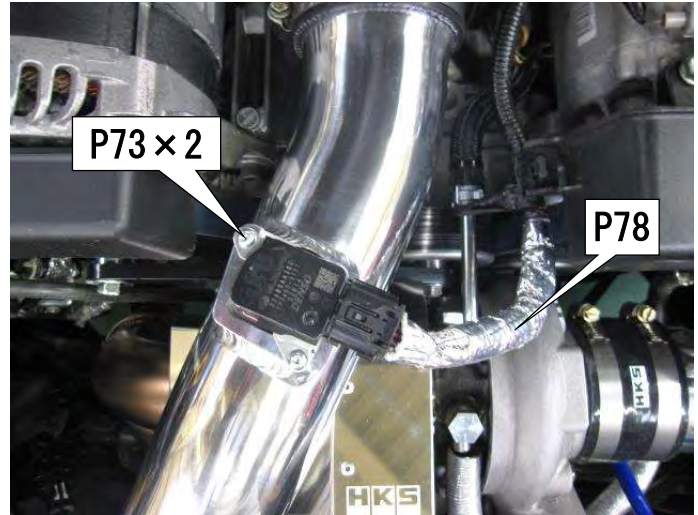

14. REINSTALLATION OF FACTORY PARTS

Use this instruction manual and the manufacturer's service manual as a reference.

PARTS LIST			
	No.	Description	QT
	P65	Flange Nut M6	1
	P66	Flange Bolt M6 L15	1
	P76	Sponge Sheet 50mm×50mm	2

- (1) Affix the Sponge Sheet to the back of the radiator support around the pipe.

- P76: Sponge Sheet 50mm×50mm x 2

- (2) Reinstall the radiator support.

NOTE

Adjust each pipe's position so the radiator support does not come in contact with the pipe.

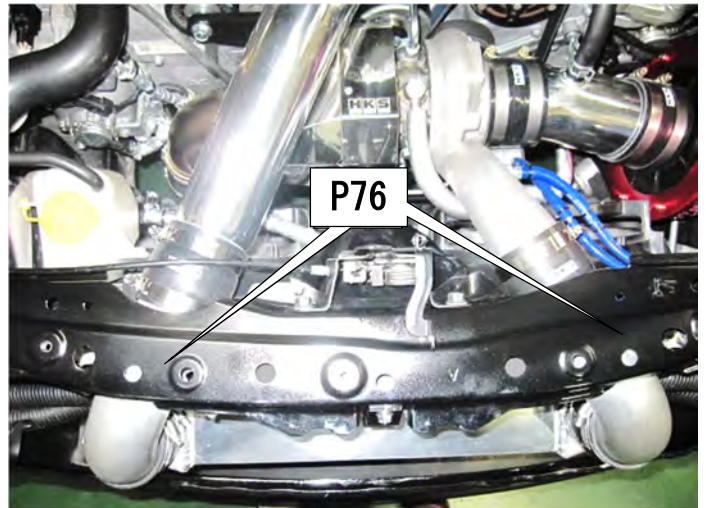

- (3) Install the Intercooler Bracket No.4 installed in 12.(6) to the radiator support using the provided Flange Bolt M6 L15.

- P66: Flange Bolt M6 L15 x 1

NOTE

Make sure the intercooler and pipes do not come in contact with any other parts of the vehicle.

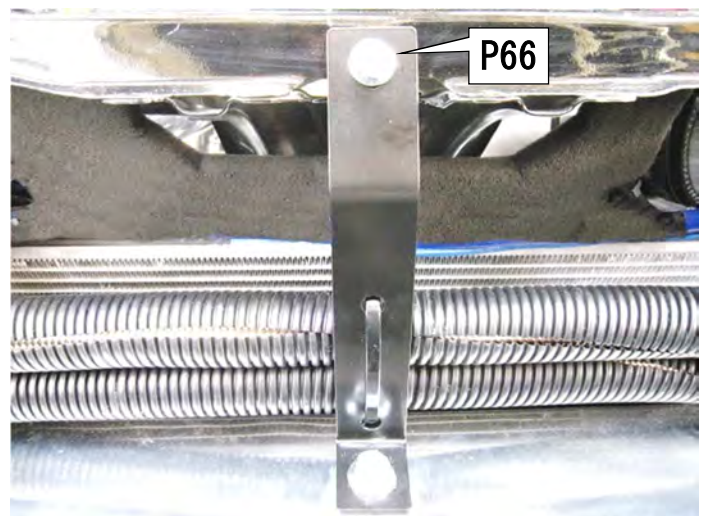

- (4) Install the horn to the bolt installed to the reinforcement in 2.(2) using the provided Flange Nut M6.

- P65: Flange Nut M6 x 1

NOTE

The photo on the right shows the vehicle with the oil cooler kit that is available separately.

Make sure each part does not come in contact with any other parts of the vehicle.



(5) Relocate the sponge on the hood support rod to the position shown in the photo on the right.

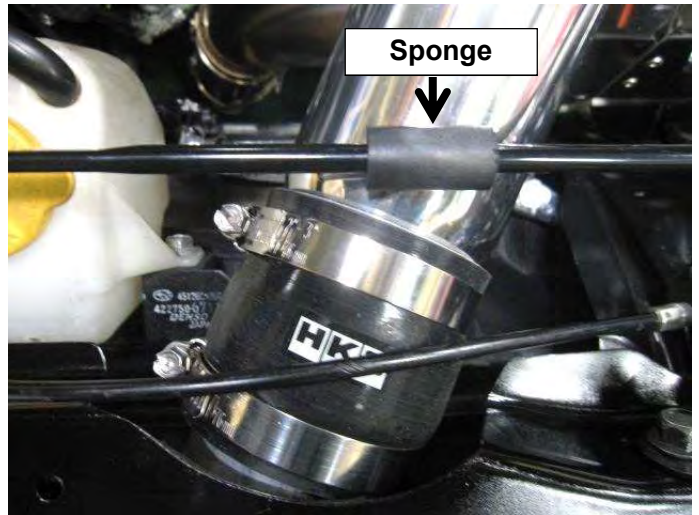

(6) Reinstall ⑧ front bumper bracket and ⑦ front bumper cover.

(7) Reinstall ③ front bumper energy absorber.

(8) Reinstall ② front bumper.

(9) Reinstall ① side-mounted turn signal to both side.

(10) Reinstall the engine under cover.

(11) Reconnect the negative cable to the battery.

(12) Refill the engine oil and coolant.

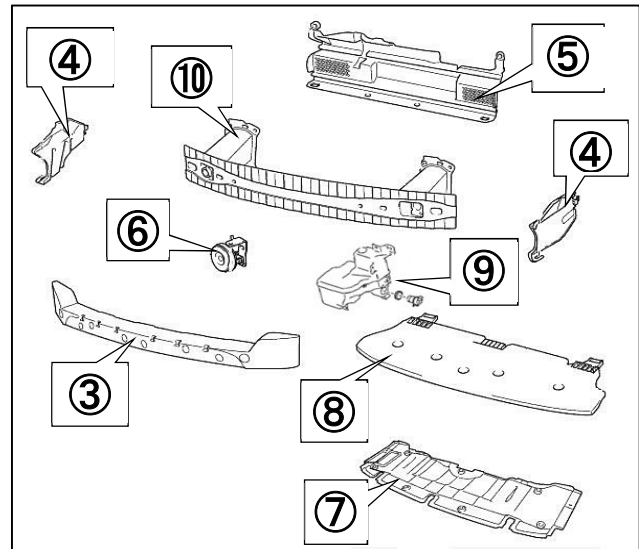
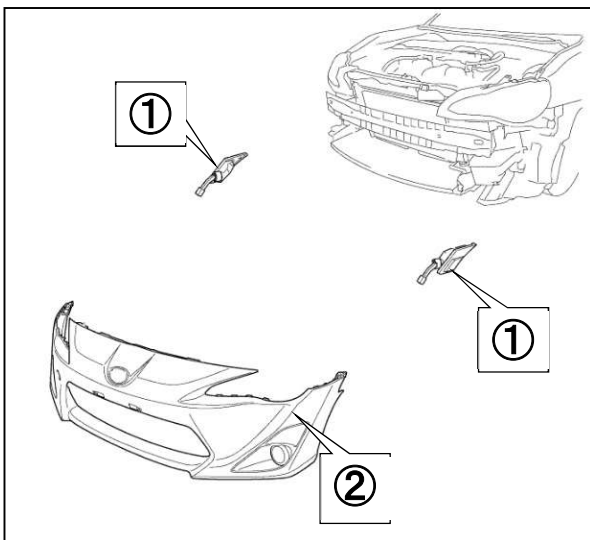

15. CONFIRMATION AFTER INSTALLATION

- Use the insulator sheet included in this kit to affix to high temperature areas around the turbocharger, exhaust parts, etc.
 - P77, P78: Insulator Sheet/

- Use the tie wraps and sponge sheet included in this kit to prevent unnecessary contact between the parts.
 - P74, P75: Tie Wrap ▪ P76: Sponge Sheet

- After the installation process is complete, check all items listed in the “Confirmation after Installation” section of the Instruction Manual.



HKS Co., Ltd.

7181 Kitayama, Fujinomiya, Shizuoka 418-0192, Japan

<https://www.hks-power.co.jp/>